

**General Standards Corporation**  
**High Performance Bus Interface Solutions**

Rev: 030222

***PCIe-16AO16C***

**16-BIT, 16-CHANNEL, HIGH-SPEED  
PCIe ANALOG OUTPUT BOARD**

*With Balanced Differential Outputs*

---

**REFERENCE MANUAL**

## TABLE OF CONTENTS

<u>SECTION</u>	<u>TITLE</u>	<u>PAGE</u>
<b>1.0</b>	<b>INTRODUCTION</b>	<b>1-1</b>
<b>1.1</b>	<b>General Description</b>	<b>1-1</b>
<b>1.2</b>	<b>Functional Overview</b>	<b>1-2</b>
<b>2.0</b>	<b>INSTALLATION AND MAINTENANCE</b>	<b>2-1</b>
<b>2.1</b>	<b>Board Configuration</b>	<b>2-1</b>
<b>2.2</b>	<b>Installation</b>	<b>2-1</b>
2.2.1	Physical Installation	2-1
2.2.2	Input/Output Cable Connections	2-2
<b>2.3</b>	<b>System Configuration</b>	<b>2-3</b>
2.3.1	Output Considerations	2-3
2.3.1.1	Output Configurations	2-3
2.3.1.2	Line Losses	2-4
2.3.1.3	Remote Ground Sensing	2-4
2.3.2	External Clock and Trigger I/O	2-5
2.3.2.1	Sample Clock Output	2-5
2.3.2.2	Burst Trigger I/O	2-5
2.3.3	Multiboard Synchronization	2-5
2.3.3.1	Synchronized Bursts	2-5
2.3.3.2	Synchronized Clocks	2-5
<b>2.4</b>	<b>Maintenance</b>	<b>2-6</b>
<b>2.5</b>	<b>Reference Verification</b>	<b>2-6</b>
2.5.1	Equipment Required	2-7
2.5.2	Verification Procedure	2-7
<b>3.0</b>	<b>CONTROL SOFTWARE</b>	<b>3-1</b>
<b>3.1</b>	<b>Introduction</b>	<b>3-1</b>
<b>3.2</b>	<b>Board Control Register</b>	<b>3-1</b>
<b>3.3</b>	<b>Configuration and Initialization</b>	<b>3-1</b>
3.3.1	Board Configuration	3-1
3.3.2	Initialization	3-3

## TABLE OF CONTENTS (Continued)

<u>SECTION</u>	<u>TITLE</u>	<u>PAGE</u>
<b>3.4</b>	<b>Analog Output Control</b>	<b>3-4</b>
3.4.1	Data Organization	3-5
3.4.1.1	Active Channels	3-5
3.4.1.1.1	Selection	3-5
3.4.1.1.2	Loading	3-5
3.4.1.2	Data Frame	3-6
3.4.1.3	Output Data Format	3-6
3.4.1.3.1	Output Data Buffer	3-6
3.4.1.3.2	Output Data Coding	3-7
3.4.1.4	Voltage Range Selection	3-7
3.4.2	Output Buffer	3-7
3.4.2.1	Buffer Operations Register	3-7
3.4.2.2	Active Buffer	3-9
3.4.2.3	Status Flags	3-9
3.4.2.4	Open Buffer	3-9
3.4.2.5	Circular Buffer	3-10
3.4.3	Output Clocking	3-11
3.4.3.1	Clock Source	3-11
3.4.3.1.1	External Clock	3-11
3.4.3.1.2	Internal Rate Generator	3-11
3.4.3.2	Simultaneous Clocking	3-12
3.4.3.3	Sequential Operation	3-12
3.4.4	Sampling Mode	3-12
3.4.4.1	Continuous Sampling	3-12
3.4.4.2	Data Bursts	3-13
3.4.5	Multiboard Synchronization	3-13
3.4.5.1	Synchronous Bursts	3-13
3.4.5.2	Synchronous Clocking	3-14
3.4.6	Function Generation	3-14
3.4.6.1	Periodic and One-Shot Functions	3-14

## TABLE OF CONTENTS (Continued)

<u>SECTION</u>	<u>TITLE</u>	<u>PAGE</u>
3.4.6.2	Multiple Functions	3-14
3.4.6.3	Functioning Sequencing	3-14
<b>3.5</b>	<b>Autocalibration</b>	<b>3-16</b>
<b>3.6</b>	<b>Interrupt Control</b>	<b>3-16</b>
3.6.1	Local Interrupt Request	3-16
3.6.2	Enabling the PCIe Interrupt	3-17
<b>3.7</b>	<b>Remote Ground Sensing</b>	<b>3-17</b>
<b>3.8</b>	<b>Application Examples</b>	<b>3-18</b>
3.8.1	Sequential Direct Outputs	3-19
3.8.2	Simultaneous Direct (Single Group) Outputs	3-19
3.8.3	Continuous Function	3-20
3.8.4	Periodic Function	3-21
3.8.5	Function Burst	3-22
3.8.6	Function Sequencing	3-23
<b>3.9</b>	<b>Buffer DMA Operation</b>	<b>3-24</b>
<b>3.10</b>	<b>Synchronization with Sigma-Delta Input Products</b>	<b>3-25</b>
3.10.1	Adjustable Reference Frequency Control	3-25
3.10.2	Initiator/Target Configurations	3-26
<b>3.11</b>	<b>Assembly Configuration Register</b>	<b>3-27</b>
<b>3.12</b>	<b>Selecting External Control-I/O Polarities</b>	<b>3-27</b>
<b>3.13</b>	<b>Isolating the System Control Output Pins</b>	<b>3-28</b>
<b>4.0</b>	<b>PRINCIPLES OF OPERATION</b>	<b>4-1</b>
<b>4.1</b>	<b>General Description</b>	<b>4-1</b>
<b>4.2</b>	<b>Analog Outputs</b>	<b>4-2</b>
<b>4.3</b>	<b>Autocalibration</b>	<b>4-2</b>
<b>4.4</b>	<b>Power Control</b>	<b>4-2</b>
<b>Appendix A</b>	<b>Local Register Quick Reference</b>	<b>A-1</b>
<b>Appendix B</b>	<b>Migration from the PCIe-16AO16</b>	<b>B-1</b>

## LIST OF ILLUSTRATIONS

<b>FIGURE</b>	<b>TITLE</b>	<b>PAGE</b>
1.1-1	Physical Configuration	1-1
1.2-1	Functional Organization	1-2
2.2-2	System I/O Connector	2-2
2.3-1	Output Configurations	2-3
2.3-2	Line Loss Versus Load Current	2-4
2.3-3	Multiboard Burst Synchronization	2-6
3.4-1	Typical Buffer Loading Sequence	3-6
3.4-2	Open Buffer Data Flow	3-10
3.4-3	Circular Buffer Data Flow	3-10
3.4-4	Function Sequencing	3-15
4.1-1	Functional Block Diagram	4-1

## LIST OF TABLES

<b>TABLE</b>	<b>TITLE</b>	<b>PAGE</b>
2.2-1	System I/O Connector Pin Functions	2-2
2.5.1	Reference Verification Equipment	2-7
3.1-1	Control and Data Registers	3-1
3.2-1	Board Control Register	3-2
3.3-1	Configuration Operations	3-3
3.4-1	Summary of Output Control Parameters	3-4
3.4-2	Channel Selection Register	3-5
3.4-3	Output Data Buffer	3-6
3.4-4	Output Data Coding; D15..D00	3-7
3.4-5	Buffer Operations Register	3-8
3.4-6	Active Buffer Size	3-9
3.4-7	Sample Rate Control Register	3-11
3.4-8	Sample Rate Selection	3-12
3.6-1	Interrupt Event Selection	3-17
3.8-1	Summary of Operation Examples	3-18
3.8-2	Initial Operations	3-18
3.8-3	Sequential Direct Outputs Example	3-19
3.8-4	Simultaneous Direct Outputs Example	3-19
3.8-5	Continuous Function Example	3-20
3.8-6	Periodic Function Example	3-21
3.8-7	Function Burst Example	3-22
3.8-8	Function Sequencing Example	3-23
3.10-1	Adjustable Reference Frequency Control Register	3-25
3.10-2	Multiboard Clocking Configurations	3-26
3.11-1	Assembly Configuration Register	3-27

(This page blank intentionally)

# SECTION 1.0

## INTRODUCTION

### 1.1 General Description

The PCIe-16AO16C board provides precision high-speed analog output capability for PCIe applications. Sixteen 16-bit analog output channels offer balanced differential output ranges of  $\pm 1.25V$ ,  $\pm 2.5V$ ,  $\pm 5V$  and  $\pm 10V$ , or optionally  $\pm 5V$ ,  $\pm 10V$  and  $\pm 20V$ , and can be clocked either simultaneously or sequentially at rates up to 450 KSPS (Kilosamples per second) per channel. The board is functionally and mechanically compatible with the IEEE PCI local bus specification Revision 2.3 for 32-Bit transfers with 33MHz or 66MHz PCI clocking.

Power requirements consist of +12 VDC and +3.3 VDC from the PCI Express bus in accordance with the specification, and operation over the specified temperature range is achieved with conventional cooling. Specific details of physical characteristics and power requirements are contained in the PCIe-16AO16C product specification. Figure 1.1-1 shows the general physical configuration of the board, and the arrangement of major components.

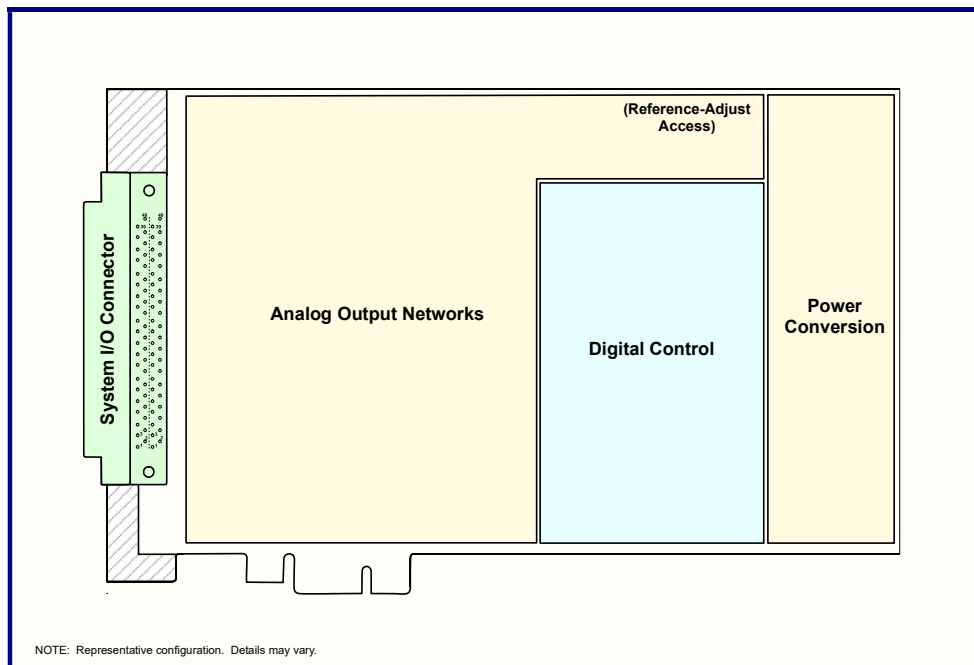

**Figure 1.1-1. Physical Configuration**

The board is designed for minimum off-line maintenance, and includes internal monitoring and autocalibration features that eliminate the need for disconnecting or removing the module from the system for calibration. All system input and output connections are made through a single 68-pin I/O connector. Analog outputs are initialized to zero-level (midrange).

## 1.2 Functional Overview

Principal capabilities of the PCIe-16AO16C board are summarized in the following list of features.

- ❑ Sixteen Precision High-Speed 3-Wire Balanced Differential Analog Output Channels
- ❑ 16-Bit Resolution; D/A Converter per Channel
- ❑ Data Rates up to 450K Samples per Second per Channel; 7.2MSPS Aggregate Rate
- ❑ Outputs Update Simultaneously or Sequentially; Software-Selectable
- ❑ Output Ranges of  $\pm 10V$ ,  $\pm 5V$ ,  $\pm 2.5V$  or  $\pm 1.25V$
- ❑ D32 Transfer Compatibility in both 33MHz and 66MHz clocking Environments
- ❑ 256K-Sample Analog Output FIFO Buffer Configurable as Either Circular or Open
- ❑ Continuous and Triggered-Burst (One-Shot) Output Modes
- ❑ Data Rate Controlled by Adjustable Internal Clock or by Externally Supplied Clock
- ❑ Supports Multiboard Synchronization.
- ❑ On-demand Internal Autocalibration of all Channels
- ❑ Differential Sync I/O Available for Synchronizing GSC's Sigma-Delta ADC Boards
- ❑ Active Buffer Size Adjustable from 8 Samples to 256K Samples.
- ❑ Analog Output Disconnects(automatic).

Figure 1.2-1 outlines the internal functional organization of the board. Sixteen analog output channels are controlled through an analog output buffer, and can be updated either simultaneously or sequentially. The outputs can be factory-configured either as 3-wire balanced differential channels or as 2-wire single-ended channels, and the output range is software-selectable as 1.25V,  $\pm 2.5V$ ,  $\pm 5V$  or  $\pm 10V$ .

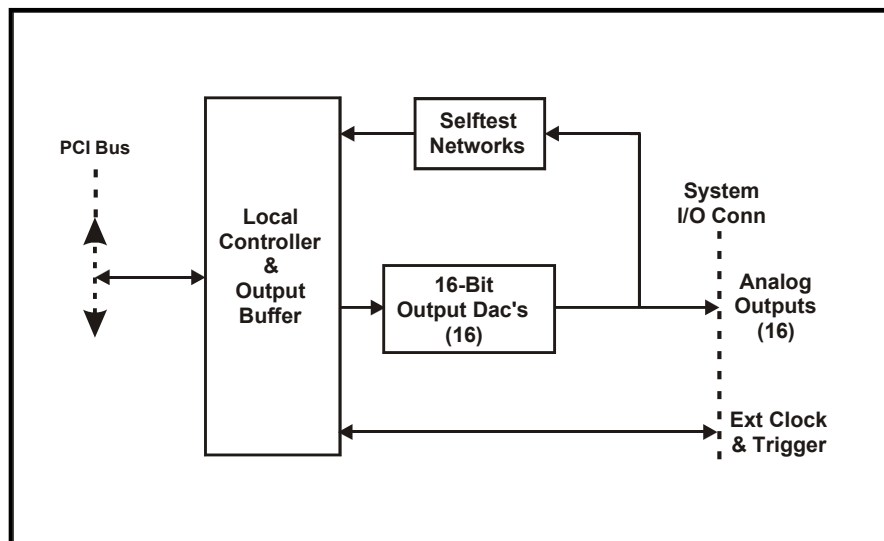

**Figure 1.2-1. Functional Organization**

The output clocking rate can be controlled by an internal rate generator, or by an external clock source. Internal selftest networks permit all channels to be calibrated to a single internal voltage reference. On-demand autocalibration adjusts offset and gain calibration DAC's in each output channel to calibrate all channels to an internal precision reference voltage.

## SECTION 2.0

### INSTALLATION AND MAINTENANCE

#### 2.1 Board Configuration

This product has no field-alterable configuration features, and is completely configured at the factory.

#### 2.2 Installation

##### 2.2.1 Physical Installation

To minimize the opportunity for accidental damage before installation, the board should be stored in the original protective shipping envelope. System power must be turned OFF before proceeding with the installation.

**CAUTION:** This product is susceptible to damage from electrostatic discharge (ESD). Before removing the board from the conductive shipping envelope, ensure that the work surface, the installer and the host board have been properly discharged to ground.

After removing the board from the shipping package, carefully press the board into position on the host. Verify that the PCIe connector has mated completely and is seated against the host board.

Secure the PCIe/PCI bracket screw carefully to complete the installation. Do not overtighten.

## 2.2.2 Input/Output Cable Connections

System cable signal pin assignments are listed in Table 2.2-1. The system input/output connector is designed to mate with a 68-Pin dual-cable high-density 0.05-inch connector, Amp type 749621-7 or equivalent. This insulation displacement (IDC) cable connector accepts standard 0.050-inch ribbon cable, with the pin numbering convention shown in Table 2.2-1 and in Figure 2.2-2. "Twist and flat" cable is recommended for long cables (greater than five feet). Contact the factory if preassembled cables are required.

**Table 2.2-1. System I/O Connector Pin Functions**

ROW-A		ROW-B	
PIN	FUNCTION	PIN	FUNCTION
1	OUTPUT 00 LO	1	OUTPUT 09 LO
2	OUTPUT 00 HI	2	OUTPUT 09 HI
3	OUTPUT RETURN	3	OUTPUT 10 LO
4	OUTPUT RETURN	4	OUTPUT 10 HI
5	OUTPUT 01 LO	5	OUTPUT RETURN
6	OUTPUT 01 HI	6	OUTPUT RETURN
7	OUTPUT RETURN	7	OUTPUT 11 LO
8	OUTPUT RETURN	8	OUTPUT 11 HI
9	OUTPUT 02 LO	9	OUTPUT 12 LO
10	OUTPUT 02 HI	10	OUTPUT 12 HI
11	OUTPUT RETURN	11	OUTPUT RETURN
12	OUTPUT RETURN	12	OUTPUT RETURN
13	OUTPUT 03 LO	13	OUTPUT 13 LO
14	OUTPUT 03 HI	14	OUTPUT 13 HI
15	OUTPUT RETURN	15	OUTPUT 14 LO
16	OUTPUT RETURN	16	OUTPUT 14 HI
17	OUTPUT 04 LO	17	OUTPUT RETURN
18	OUTPUT 04 HI	18	OUTPUT RETURN
19	OUTPUT RETURN	19	OUTPUT 15 LO
20	OUTPUT RETURN	20	OUTPUT 15 HI
21	OUTPUT 05 LO	21	OUTPUT RETURN
22	OUTPUT 05 HI	22	REM GND SENSE
23	OUTPUT RETURN	23	OUTPUT RETURN
24	OUTPUT RETURN	24	VTEST OUT
25	OUTPUT 06 LO	25	VTEST RETURN
26	OUTPUT 06 HI	26	DIGITAL RETURN
27	OUTPUT RETURN	27	TRIG IN HI *
28	OUTPUT RETURN	28	TRIG IN LO *
29	OUTPUT 07 LO	29	TRIG OUT HI *
30	OUTPUT 07 HI	30	TRIG OUT LO *
31	OUTPUT RETURN	31	DAC CLK OUT HI *
32	OUTPUT RETURN	32	DAC CLK OUT LO *
33	OUTPUT 08 LO	33	CLOCK I/O HI **
34	OUTPUT 08 HI	34	CLOCK I/O LO **

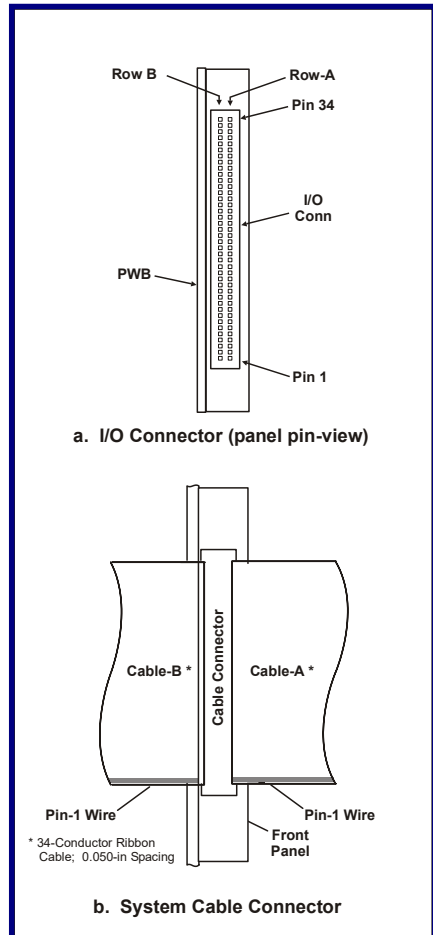

**Figure 2.2-2. System I/O Connector**

The differential analog output configuration is shown. For optional single-ended outputs, OUTPUT XX HI is an output, and OUTPUT XX LO is not used.

\* Software-selectable as LVDS differential pairs. In TTL mode, 'HI' pins are signal pins, and 'LO' inputs should be connected to digital return.

\*\* Bidirectional synchronization signal.

Channels available in 8-Channel and 12-Channel configurations:

8-Channel Board: Channels 00-07, 12-Channel board: Channels 00-11.

## 2.3 System Configuration

### 2.3.1 Output Considerations

#### 2.3.1.1 Output Configurations

The sixteen analog output channels can be factory-configured either as 3-wire balanced differential outputs or as 2-wire single-ended outputs.

Balanced differential outputs (Figure 2.3-1a) provide the highest immunity to system noise and interference, and are recommended in all systems in which the loads will accept differential inputs. Each of the HI and LO outputs carries one-half of the output signal, with the two halves operating as complementary signals of equal amplitude and opposite polarity. Since radiated interference usually affects both output lines simultaneously, the coupled interference appears as a common mode signal which will be attenuated in a differential load.

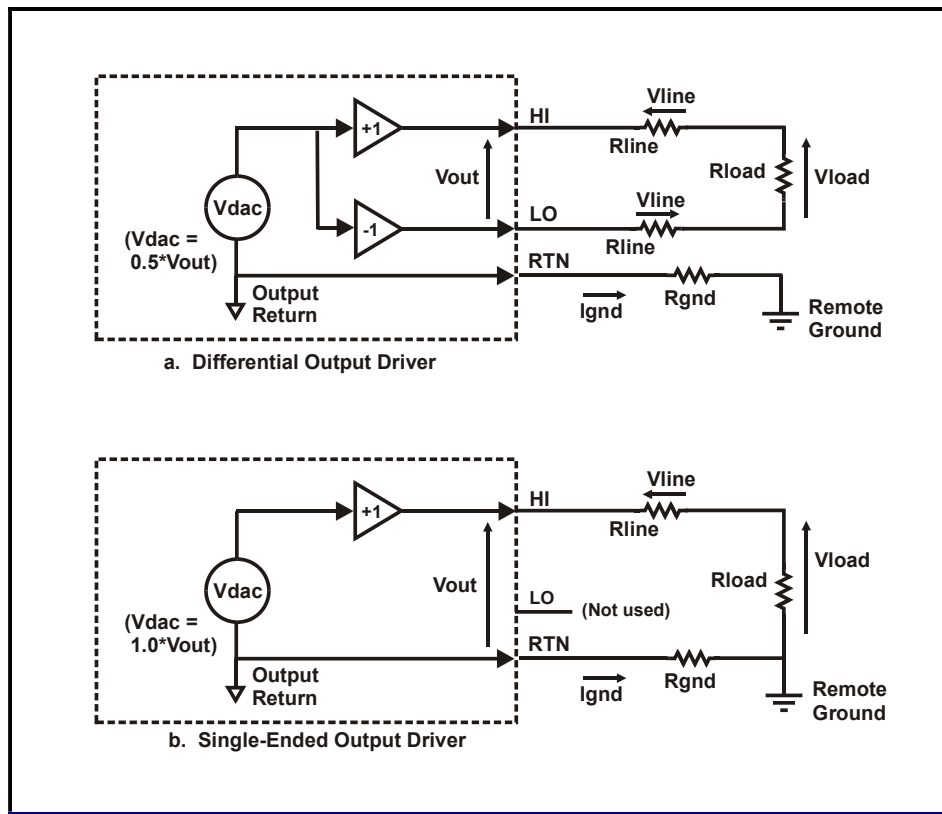
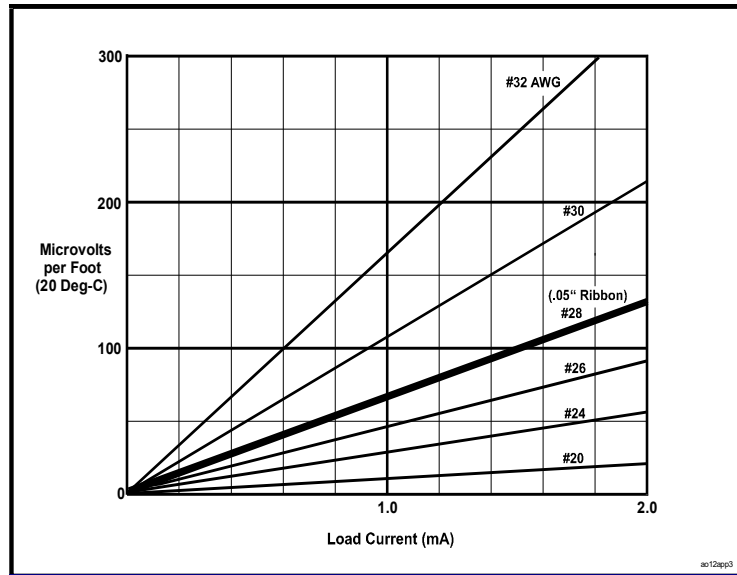

**Figure 2.3-1. Output Configurations**

For applications requiring single-ended outputs (Figure 2.3-1b), the output signal from each channel appears on the associated HI output pin, and is generated with reference to the output return pin. In general, single-ended outputs should drive only loads that are isolated from system ground. The best results are obtained when the loads also are isolated from each other

### 2.3.1.2 Line Losses

The voltage drop in ribbon cable can be a significant source of error in 16-bit systems, even with relatively short cables driving low-current loads. Figure 2.3-2 shows the effect of load current on the voltage drop in copper wire of various sizes. A 2.0 milliamp load for example, will insert a voltage drop of approximately 130 microvolts *per foot* in conventional #28 AWG ribbon cable; twice that if the return line also is considered. Several feet of ribbon cable therefore can produce significant errors in a 16-bit system, in which 1 LSB may represent only 76 microvolts ( $\pm 2.5$  Volt range). High impedance loads however, generally will not produce significant DC line loss errors.



**Figure 2.3-2. Line Loss Versus Load Current**

### 2.3.1.3 Remote Ground Sensing

In single-ended applications, if a significant potential difference is expected between the ground connection at the load and the output return from the board, the use of remote ground sensing should be considered. When remote ground sensing is enabled through application software, the input signal at the REM GND SENSE pin in the I/O connector adjusts the output voltages of single-ended channels to compensate for a ground potential at the load.

To provide correction for the potential difference between the analog output return and the remote system ground, the REM GND SENSE input must be connected to the remote system ground, and remote sensing must be enabled by the control software. If remote ground sensing is not implemented, the REM GND SENSE input should be connected to OUTPUT RETURN.

The remote sensing input affects all analog output channels, and consequently can be a significant source of noise if not adequately protected from external sources of interference.

**NOTE: Remote ground sensing is disabled for differential output channels.**

### 2.3.2 External Clock and Trigger I/O

External clock and trigger input and output signals are software-selectable as either single-ended TTL-compatible, or as low-voltage differential signaling (LVDS)-compatible.

In LVDS mode, the HI and LO pins in each pair correspond to the standard "+" and "-" LVDS signals, respectively. LVDS inputs are terminated internally with 100 Ohms.

In TTL mode, the clock and trigger signals use the corresponding "HI" I/O pins, and the "LO" pins should be grounded to digital return. TTL inputs are pulled HIGH internally through approximately 5K-Ohms

**NOTE: Polarities of external control signals: TRIG IN, TRIG OUT, DAC CLK OUT, and CLOCK I/O, can be inverted individually in software.**

#### 2.3.2.1 Sample Clock Output

The DAC CLOCK OUT signal generates a 100-150ns low-going pulse each time the analog outputs are updated, and can be used to synchronize the analog output clocking of multiple *clock target* boards to a single *clock initiator*.

#### 2.3.2.2 Burst Trigger I/O

If burst triggering is enabled by the control software, an external TTL or LVDS signal can initiate a data burst by applying a HIGH-to-LOW transition on the TRIGGER INP pin in the I/O connector. In order for the trigger input to be acknowledged, the TRIGGER OUT signal must be HIGH, and the TRIGGER INP signal must go low for a minimum interval of 70 nanoseconds.. TRIGGER OUT goes LOW at the beginning of a burst, and returns HIGH when the burst is completed.

To use the TRIGGER OUT as the *sync* input to an SDI-series sigma-delta board, connect the TRIGGER OUT HI and LO outputs to the SYNC LO and HI inputs, respectively, of the SDI board.

### 2.3.3 Multiboard Synchronization

#### 2.3.3.1 Synchronized Bursts

If multiple boards are to be burst-synchronized together, the TRIGGER OUT signal from a single *burst-initiator*, is connected to the TRIGGER IN pin of the first board in a series of *burst targets* (Figure 2.3-3). The TRIGGER OUT from each target is connected to the TRIGGER IN of the next target board in the series, and the TRIGGER OUT of the last target is left unconnected. When operating in this *triggered-burst* mode, each burst-target will initiate a single burst from its buffer each time the burst-initiator initiates a burst. The initiator can be configured for either continuous or burst operation.

#### 2.3.3.2 Synchronized Clocks

To clock-synchronize multiple boards together, the DAC CLOCK OUT from a *clock initiator* is connected directly to the CLOCK IO pin of the first target board in a series of *clock targets*. The DAC-CLOCK OUT from each target is connected to the CLOCK IO pin of the next target in the series, and the CLOCK-IO pin of the last target is left unconnected. This mode is configured by the application software as shown in Table 3.10-2.

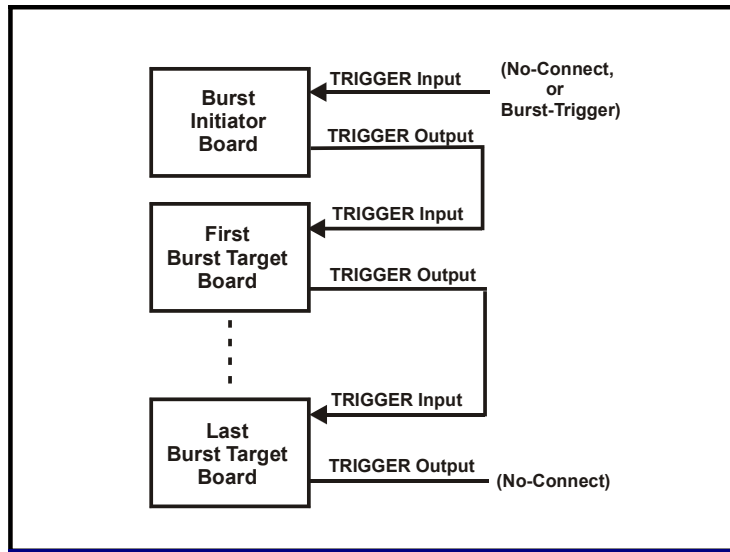

**Figure 2.3-3. Multiboard Burst Synchronization**

A clock target can be clocked by a HI-to-LO transition from any external TTL or LVDS signal source connected to the CLOCK IO input. The input signal is edge-detected, and must be low for a minimum interval of 70 nanoseconds in order to be recognized as a valid clock.

## 2.4 Maintenance

This product requires no scheduled hardware maintenance other than periodic reference verification. The optimum verification interval will vary, depending upon the specific application, but in most instances an interval of one year should be sufficient. In the event of a suspected malfunction, all associated system parameters, such as power voltages, control bus integrity, and input signal levels, should be evaluated before troubleshooting of the board itself is attempted. A board that is suspected to be defective should be returned to the factory for problem analysis and repair.

## 2.5 Reference Verification

All output channels are software-calibrated to an internal voltage reference ( $V_{test}$ ) by an embedded autocalibration firmware utility. The verification procedure presented here describes the adjustment of the reference. For applications in which the system must not be powered down, the board can be calibrated under normal operating conditions while installed on the existing host board.

To eliminate the requirement for a special test connector, the two test points required for calibration,  $V_{TEST}$  OUT and  $V_{TEST}$  RETURN, can be made available at a system breakout connector or test panel. This arrangement also eliminates the necessity of disconnecting the system input/output cable for reference verification or adjustment.

### 2.5.1 Equipment Required

Table 2.5-1 lists the minimum equipment requirements for verifying and adjusting the internal voltage reference. Alternative equivalent equipment may be used.

**Table 2.5-1. Reference Verification Equipment**

<b>EQUIPMENT DESCRIPTION</b>	<b>MANUFACTURER</b>	<b>MODEL</b>
Digital Multimeter, 5-1/2 digit, 0.005% accuracy for DC voltage measurements at $\pm 10$ Volts.	Hewlett Packard	34401A
Host board with PCI Express slot	(Existing host)	---
Standard 68-Pin, 0.05", dual-ribbon cable connector, with test leads. (Not required if calibration test points are made permanently available at a system connection point)	Amp	#1-746288-0

### 2.5.2 Verification Procedure

The following procedure describes the single adjustment that is necessary to ensure conformance to the product specification.

Adjustment of the internal reference is performed with a single adjustment trimmer that is located at the top edge of the board. The adjustment seal on the trimmer should be removed before beginning the procedure, and the trimmer should be resealed with a suitable sealing agent after the adjustment has been completed. Thread-locking agents *should not* be used.

This procedure assumes that the board to be verified is installed in a suitable host. The board can be operating in any mode when the adjustment is performed.

1. Connect the digital multimeter between the VTEST OUT (+) and VTEST RETURN (-) pins in the system I/O connector.
2. If power has been removed from the board, apply power now and wait at least 15 minutes before proceeding.
3. The digital multimeter indication should indicate  $+9.9900 \pm 0.0009$  VDC. If the indication is not within this range, adjust the reference trimmer until an in-range indication is obtained..
4. Reference verification or adjustment is completed. Remove all test connections.

## SECTION 3.0 CONTROL SOFTWARE`

### 3.1 Introduction

The PCIe-16AO16C compatible with the PCI Local Bus specification revision 2.3 for D32 transfers at 66MHz. The PCI interface is controlled by a PLX™ PCI-9056 PCI adapter. The PCIe interface is provided by the IDT TSi381 and meets PCIe Bus specification revision 1.1. Configuration space registers are initialized internally to support the location of the board in memory space.

After initialization has been completed, communication between the PCI Express bus and the local bus takes place through the control and data registers shown in Table 3.1-1. All local data transfers are long-word D32. Any of the predefined operational conditions identified throughout this section can invoke a single interrupt request from the board. DMA access is supported for data transfers to the output data buffer. To ensure compatibility of applications with subsequent product upgrades, reserved bits should be written LOW.

**Table 3.1-1. Control and Data Registers**

Offset	Register	Mode*	Default	Primary Function
00	BOARD CONTROL (BCR)	R/W	0000_0810h	Board Control Register (BCR)
04	CHANNEL SELECTION	R/W	0000_FFFFh	Channel-enabling mask
08	SAMPLE RATE	R/W	0000_0096h	Analog output clocking rate selection
0C	BUFFER OPERATIONS	R/W	0000_340Fh	Buffer size selection and status flags
10	ASSEMBLY CONFIGURATION **	RO	00XX_XXXXh	Firmware revision and hardware options
14	Autocal Values **	R/W	0000_0XXXh	---
18	OUTPUT DATA BUFFER	WO	0000_0000h	Analog output FIFO buffer
1C	ADJUSTABLE CLOCK	R/W	0000_0000h	Control of the adjustable clock generator.

\* R/W = Read/Write; RO = Read-only; WO = Write-only .

\*\* Maintenance register; shown for reference.

### 3.2 Board Control Register

The Board Control Register (BCR) controls primary board functions, including burst control, autocalibration, and interrupt event selection. Table 3.2-1 provides a brief description of each bit field in the BCR, as well as indicating an associated section in the text.

### 3.3 Configuration and Initialization

#### 3.3.1 Board Configuration

During *board configuration*, initial values for both the PCI configuration registers and the internal control logic are extracted from internal nonvolatile read-only memory. This process is initiated by a PCI bus reset, and should be required only once after the initial application of power. While the

PCI configuration registers are being loaded, the response to PCI target accesses is RETRY's. Configuration operations are executed in the sequence shown in Table 3.3-1.

**Table 3.2-1. Board Control Register**

**Offset: 0000h**

**Default: 0000\_0810h**

Bit	Mode	Designation	Def	Description	Ref
D00	R/W	BURST ENABLED	0	Selects burst-mode if HIGH, continuous-mode if LOW.	3.4.4, 3.4.5
D01	RO	BURST READY	0	If HIGH, indicates that a burst trigger will be accepted. If LOW, indicates that a burst is in progress, and that a trigger will not be accepted. Available as an interrupt condition.	
D02	R/W	*BURST TRIGGER	0	Software burst trigger, asserted HIGH. Active only when BURST ENABLED control bit is asserted.	
D03	R/W	REMOTE GROUND SENSE	0	Correction is made for remote ground potentials when this bit is HIGH.	3.7
D04	R/W	OFFSET BINARY	1	Selects offset-binary data format when asserted HIGH, or two's complement when LOW.	3.4.1.3
D05	R/W	DIFFERENTIAL SYNC I/O	0	Selects differential (LVDS) external clock and trigger I/O when high, or TTL clock and trigger I/O when low.	3.4.5
D06	R/W	DISABLE EXT BURST TRIG	0	Disables external burst trigger input.	3.4.4.2
D07	R/W	SIMULTANEOUS OUTPUTS	0	When HIGH, selects simultaneous output clocking. When LOW, selects sequential clocking. Default is LOW; i.e.: sequential clocking.	3.4.3.2, 3.4.3.3
D08-D10	R/W	INTERRUPT A0-A2	0	Interrupt event selection.	3.6
D11	R/W	INTERRUPT REQUEST FLAG	1	Set HIGH when the board asserts an interrupt request. Clears the request when cleared LOW by the bus.	
D12	R/W	(Reserved)	0	---	---
D13	R/W	AUTOCALIBRATION <sup>1</sup>	0	Initiates autocalibration. Completion is available as an interrupt condition.	3.5
D14	RO	AUTOCAL STATUS FLAG	0	Records the status of autocalibration; LOW for pass, HIGH for fail.	
D15	R/W	INITIALIZE <sup>1</sup>	0	Initializes the board when set HIGH. Sets all defaults for all registers.	3.3.2
D16-D17	R/W	OUTPUT RANGE	0	Selects the output voltage range as: 0 => ±1.25V, or (Reserved) * 1 => ±2.5V, or ±5V * 2 => ±5V, or ±10V * 3 => ±10V, or ±20V * * With the High-Level Differential outputs option.	3.4.1.4
D18	R/W	INVERT TRIGGER INPUT	0	Inverts the external TRIG IN signal	3.12
D19	R/W	INVERT TRIGGER OUTPUT	0	Inverts the external TRIG OUT signal	
D20	R/W	INVERT DAC CLOCK OUT	0	Inverts the external DAC CLK OUT signal	
D21	R/W	INVERT CLOCK I/O	0	Inverts the external CLOCK I/O in/out signals	
D22	R/W	WATCHDOG BIT ENABLE	0	Replaces the normal Trigger output at the TRIG OUT HI/LO pins with the WATCHDOG OUTPUT control bit.	(FW-003B Only)
D23	R/W	WATCHDOG OUTPUT	0	Watchdog monitor control bit. Available as TRIG OUT HI/LO in the system I/O connector.	
D24-D31	RO	(Reserved)	0	Inactive. Returns all-zero.	---

<sup>1</sup> Cleared automatically when operation is completed.

R/W = Read/Write; RO=Read-Only.

Board configuration terminates with the PCI interrupts disabled. Attempts to access the local bus during configuration should be avoided until the PCI interrupts are enabled and an initialization-complete interrupt request is asserted.

**Table 3.3-1. Configuration Operations**

Operation	Maximum Duration
PCI configuration registers are loaded from internal ROM	3 ms
Internal control logic is configured from internal ROM	300 ms
Internal control logic is initialized	3 ms

Loading of the PCI configuration registers is completed within 3 milliseconds or less after the assertion of a PCIe bus reset, and should be required only once after the initial application of power. PCI register configuration terminates with the PCI interrupts disabled (Paragraph 3.6).

### 3.3.2 Initialization

Internal control logic can be initialized without invoking configuration by setting the INITIALIZE control bit in the BCR. This action causes the internal logic to be initialized, but does not affect the PCI configuration registers and does not reconfigure the internal control logic. Initialization requires 3 milliseconds or less for completion, and produces the following default conditions:

- The BCR is initialized; all defaults are invoked (Paragraph 3.2),
- All analog outputs are set to zero-level (3.4.1.1),
- All channels are active (3.4.1.1.1),
- Data coding format is offset binary (3.4.1.3.2),
- The  $\pm 1.25V$  output range is selected (3.4.1.4),
- The analog output buffer is reset to empty (3.4.2),
- Buffer configuration is open (3.4.2.4), with maximum size selected (3.4.2.2),
- Internal clocking is selected (3.4.3.1), and clocking is disabled (3.4.3),
- The clocking rate generator is adjusted to 300KSPS (3.4.3.1.2),
- Clocking mode is sequential (3.4.3.3) and continuous (3.4.4.1),
- TTL sync I/O logic is selected (3.4.5),
- The local interrupt request is asserted (ignored unless PCI interrupts are enabled) (3.6),
- Remote ground sensing is disabled (3.7).
- The adjustable clock rate generator is disabled (3.10),

Upon completion of initialization, the INITIALIZE control bit in the BCR is cleared automatically.

### 3.4 Analog Output Control

This section describes those operations that control the movement of data from the PCI bus through the analog output buffer. These functions include the selection of active channels, the organization of data within the buffer, and the clocking of data from the buffer to the analog outputs. The principal parameters associated with controlling the analog output channels are summarized below in Table 3.4-1. Section 3.8 provides detailed examples of analog output operations.

**Table 3.4-1. Summary of Output Control Parameters**

Parameter	Mode	Description
Data Control	Active Channels; <b>Channel Group</b>	A single set of all active output channels constitutes an <b>Active Channel Group</b> . Active channels are selected under a channel mask.
	Data Frame	All data values in the buffer comprise a <i>Data Frame</i> .
	Data Coding	Output data can be coded either in offset-binary format or in two's complement format.
Active Buffer	Size Selection	The active buffer is a subset of the physical output data buffer. Active buffer size is determined by the SIZE[3..0] control-bit field in the buffer operations register.
	Status Flags	Status flags buffer-empty, buffer-low-quarter, buffer-high-quarter and buffer-full are provided for the active buffer.
Buffer Configuration	Open	Data read from the buffer is used and then discarded, until the buffer is empty.
	Circular (closed)	Data within the buffer is recirculated. Each value read from the output of the buffer FIFO is written back to the input of the FIFO. An end-of-frame (EOF) flag tracks the movement of data through the buffer.
Clock Source	External	External hardware provides the sample clock.
	Internal	The sample clock is provided by an internal rate generator, at a rate determined by the sample rate control register.
Clocking Mode	Simultaneous	At each clock occurrence, the next channel group (i.e.: a single group of all active channel values) in the output buffer is transferred to the respective analog output channels. All outputs are updated simultaneously.
	Sequential	At each clock occurrence, the next active channel value in the output buffer is transferred to the associated analog output channel, which is updated immediately.
Sampling Mode	Continuous	The contents of the output buffer are sampled continuously at the selected clock rate.
	Triggered Burst	A single data frame in the buffer is clocked to the outputs.

### 3.4.1 Data Organization

#### 3.4.1.1 Active Channels

Analog output data is loaded into the output buffer in discrete groups, or frames, of channel data. An active *channel group* consists of a single set of output values for all active channels.

Only active output channels receive data from the output buffer. A channel that is deselected to the inactive state retains the last value that was received while the channel was still active. During initialization, all channels are selected as active and are set to midrange (zero output level).

##### 3.4.1.1.1 Selection

An output channel is selected as *active* by setting the corresponding ENABLE CHANNEL XX selection bit HIGH in the Channel Selection Register, as shown in Table 3.4-2. A channel is deselected to the *inactive* state by clearing the corresponding selection bit. To select Channels 3, 9 and 14 as active for example, the Channel Selection register would have the value 0000\_4208h.

Channels 00-07 are available with 8-Channel boards, and Channels 00-11 are available with 12-Channel boards.

**Table 3.4-2. Channel Selection Register**

**Offset: 0004h**

**Default: 0000\_FFFFh**

BIT	MODE	DESIGNATION	DESCRIPTION
D00	R/W	ENABLE CHANNEL 00	Channel-Enable mask. A channel is enabled if the associated mask bit is HIGH, or is disabled if the bit is LOW.
D01	R/W	ENABLE CHANNEL 01	
D02	R/W	ENABLE CHANNEL 02	
D03	R/W	ENABLE CHANNEL 03	
D04-D15	R/W	ENABLE CHANNEL 04-15	
D16-D32	RO	(Reserved)	Inactive. Returns all-zero.

##### 3.4.1.1.2 Loading

Channel data values are loaded into the output buffer in ascending order of the active channels. The channel groups are loaded contiguously, beginning with the first group to be transferred to the outputs, and proceeding sequentially to the last group. Figure 3.4-1 illustrates a loading example that represents three active channels, with 100 values per channel. Each channel group consists of active channels 3, 6 and 8, and consequently the value in the channel selection register is 0000\_0148h.

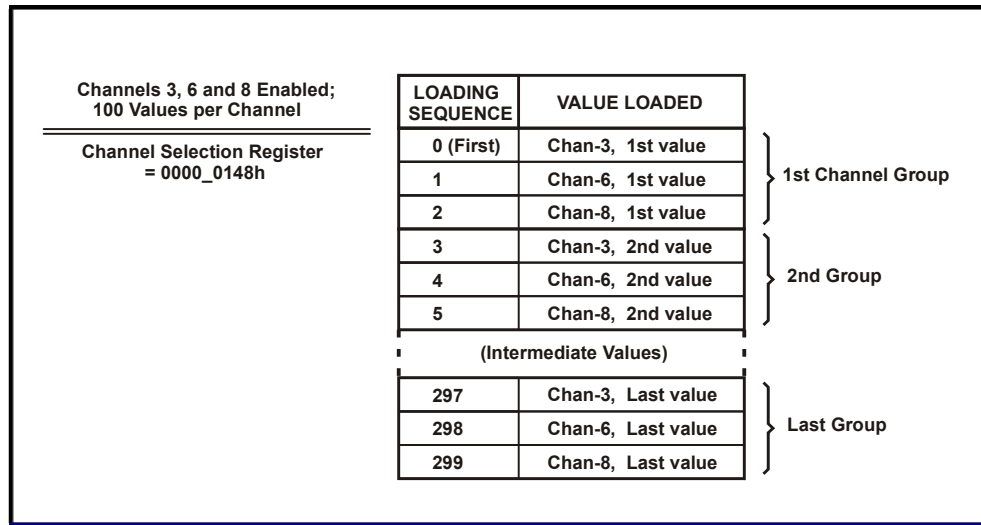

**Figure 3.4-1. Typical Buffer Loading Sequence**

### 3.4.1.2 Data Frame

A *data frame* consists of an integral number of contiguous channel groups.

For triggered bursts, or for function concatenation, the last active channel in the last channel group is designated as the *end-of-frame* (EOF). The EOF designation is applied by setting the EOF flag (D16) HIGH when loading the last channel value into the buffer. Thereafter, the EOF flag follows the last channel value through the buffer.

### 3.4.1.3 Output Data Format

#### 3.4.1.3.1 Output Data Buffer

Analog output data values are written in word-serial sequence from the PCI bus to the Output Data Buffer register shown in Table 3.4-3. Bits D15..0 represent the output data value. Bit D16 is set HIGH to indicate the last value in a data frame, and is the end-of-frame (EOF) flag. Bits D31..17 are inactive and have no effect. Access to the output buffer is supported for both single-longword transfers and single-address multiple-longword DMA transfers.

**Table 3.4-3. Output Data Buffer**

Offset: 0018h

Default: N/A (Write-Only)

BIT	MODE*	DESIGNATION	DESCRIPTION
D00	WO	DATA 00	Least significant data bit
D01-D14	WO	DATA 01 - DATA 14	Intermediate data bits
D15	WO	DATA 15	Most significant data bit
D16	WO	EOF FLAG	End-of-frame (EOF) flag.
D17-D31	WO	---	(Inactive)

\* WO indicates write-only access. Read-access returns all-zero value.

### 3.4.1.3.2 Output Data Coding

Analog output data can be coded either in 16-bit offset binary format (Table 3.4-4) by asserting the OFFSET BINARY control bit HIGH in the BCR, or in two's complement format by clearing the control bit LOW. Analog output data transactions are D32 (32 bits), but the data significance is 16 bits.

**Table 3.4-4. Output Data Coding; D15..D00**

ANALOG OUTPUT LEVEL	DIGITAL VALUE (Hex)	
	OFFSET BINARY	TWO'S COMPLEMENT
Positive Full Scale minus 1 LSB	XXXX FFFF	XXXX 7FFF
Zero plus 1 LSB	XXXX 8001	XXXX 0001
Zero	XXXX 8000	XXXX 0000
Zero minus 1 LSB	XXXX 7FFF	XXXX FFFF
Negative Full Scale plus 1 LSB	XXXX 0001	XXXX 8001
Negative Full Scale	XXXX 0000	XXXX 8000

*Positive Full Scale* is a positive level that equals the range option defined for the board (e.g.: +5.000 Volts for the  $\pm 5V$  option). *Negative Full Scale* is the negative equivalent of positive full-scale. *Full-scale Range* (FSR) is the total voltage range for the output channel. One LSB equals the full-scale range divided by 65,536. (e.g.: 152.59 microvolts for the  $\pm 5V$  option).

### 3.4.1.4 Voltage Range Selection

The output voltage range for all channels is selected as  $\pm 10V$ ,  $\pm 5V$ ,  $\pm 2.5V$  or  $\pm 1.25V$  with the OUTPUT RANGE control field in the BCR. To minimize potential stresses on sensitive load networks, the board initializes to the lowest range of  $\pm 1.25V$ .

For maximum accuracy, autocalibration should always be performed after a new output range is selected.

**NOTE: An optional configuration provides high-level differential output ranges of  $\pm 20V$ ,  $\pm 10V$  or  $\pm 5V$ . This option is available with firmware revision FW-008 and higher.**

## 3.4.2 Output Buffer

The *physical output buffer* consists of a 17-bit wide FIFO that has a capacity of 256K output values. Each output value is 16 bits wide and occupies a single location within the FIFO. The 17th bit is an end-of-frame flag that is attached to the last value in a data frame (Table 3.4-3). Data values are transferred from the PCI bus to the analog output channels through an *active buffer*, which is a subset of the physical buffer.

### 3.4.2.1 Buffer Operations Register

The *buffer operations register* (BOR) controls the configuration of the output buffer, as well as related functions such as clocking and loading.

**Table 3.4-5. Buffer Operations Register**

Offset: 000Ch

Default: 0000\_340Fh

Bit	Mode	Designation	Def	Description	Ref
D00-D03	R/W	SIZE 00-SIZE 03	Fh	Size-selection bit field for the active buffer. Defaults to 256K Samples.	3.4.2.2
D04	R/W	EXTERNAL CLOCK	0	Selects hardware or software clock source when HIGH, or the internal rate generator when LOW. Default is LOW (internal rate generator).	3.4.3.1.1
D05	R/W	ENABLE CLOCK	0	Enables output clocking when HIGH. Disables clocking when LOW. Default is LOW (clocking disabled).	3.4.3
D06	RO	CLOCK READY	0	If external clocking is selected, indicates when HIGH that a hardware or software clock will be accepted. If LOW, indicates that the output is not ready to accept a clock. Active only when external clocking is selected.	3.10.1
D07	R/W	* SW CLOCK	0	If external clocking is selected, produces a single output clock event when asserted. Clears LOW automatically when the clock event is completed. Active only when external clocking is selected.	3.4.3.1.1
D08	R/W	CIRCULAR BUFFER	0	Selects circular buffer configuration if HIGH, or open self-flushing buffer configuration if LOW. Access for loading new data into the circular buffer must be requested by asserting LOAD REQUEST. Default is LOW; i.e. open buffer.	3.4.2.5
D09	R/W	* LOAD REQUEST	0	When set HIGH, requests loading access to the circular buffer. Initializes LOW.	3.4.6.3
D10	RO	LOAD READY	1	Set HIGH when the frame index passes through zero, if both CIRCULAR BUFFER and LOAD REQUEST are HIGH. When HIGH, indicates that the circular buffer is ready to accept new data. Available as an interrupt condition. Defaults HIGH.	
D11	R/W	* CLEAR BUFFER	0	Resets the buffer to empty.	3.4.2.2
D12	R/W	BUFFER EMPTY	1	Status flags for the active buffer. Empty, lo-quarter and hi-quarter flags are available as interrupt events.	3.4.2.3
D13	RO	BUFFER LOW QUARTER	1		
D14	RO	BUFFER HIGH QUARTER	0		
D15	RO	BUFFER FULL	0		
D16	R/W	BUFFER OVERFLOW	0	Set HIGH when data is written to a full buffer. **	
D17	R/W	FRAME OVERFLOW	0	Set HIGH when data is written to a closed buffer. **	
D18	R/W	ISOLATE TRIG OUT	0	Each control bit configures the corresponding external pin pair as a static Logic-LOW output.	3.13
D19	R/W	ISOLATE DAC CLK OUT	0		
D20	R/W	ISOLATE CLOCK IO	0		
D21-D31	RO	(Reserved)	0	Inactive. Returns all-zero.	---

\* Clears LOW automatically when operation is completed.

\*\* Remains HIGH until cleared by a direct write as LOW, or by initialization.

### 3.4.2.2 Active Buffer

The *active buffer* is a virtual buffer that represents a subset of the physical buffer, and which is the working buffer through which all output data flows. The size of the active buffer is adjustable from eight values up to the full size of the physical buffer. The buffer can be cleared to the empty state by setting the CLEAR BUFFER control bit HIGH in the buffer operations register. CLEAR BUFFER clears automatically after the reset operation has been completed.

**NOTE: Data loss may occur if the buffer is allowed to fill completely.**

The active buffer performs exactly like a physical buffer of the same size. That is, a full buffer will accept no further data from the bus, and an empty buffer indicates that all outputs are idle. Buffer status flags (empty, low-quarter, high-quarter and full) respond to the size of the *active buffer*, not to the size of the physical buffer.

Active buffer size is determined by the SIZE[3..0] control bit field in the buffer operations register. Available active buffer sizes are listed in Table 3.4-6.

**Table 3.4-6. Active Buffer Size**

SIZE[3:0]	BUFFER SIZE (Total Channel Values)	SIZE[3:0]	BUFFER SIZE (Total Channel Values)
0	8	8	2048
1	16	9	4096
2	32	A	8192
3	64	B	16384
4	128	C	32768
5	256	D	65536
6	512	E	131072
7	1024	F	262144

### 3.4.2.3 Status Flags

Status flags for the buffer operate with respect to the active buffer, and can initiate an interrupt request if the active buffer becomes empty, 3/4-full, or less than 1/4-full. These flags are located in the buffer operations register (Table 3.4-5), and are available as interrupt events (Table 3.6-1).

The BUFFER OVERFLOW flag is set HIGH if data is written to a full buffer, and the FRAME OVERFLOW flag indicates that an attempt was made to write data to a closed buffer, each indicating data loss. Once set, each of these flags remains HIGH until written LOW directly from the bus, or by initialization .

### 3.4.2.4 Open Buffer

Data in an open buffer is discarded as it is used. Consequently, the buffer is self-flushing, and will empty itself unless it is replenished from the bus. This mode of operation permits the continuous flow of data from the PCI bus to the analog outputs. The buffer status flags are useful in this situation, and provide an indication of whether the buffer is empty, less than 1/4 full (low-quarter), greater than 3/4 full (high-quarter), or full. A full buffer will discard additional data from the bus, while an empty buffer indicates that the outputs are idle. The low-quarter and high-quarter flags are used to control data flow through the buffer when generating continuous functions.

The open-buffer configuration also can be used to produce a one-shot waveform, provided the particular waveform is to be used only once. Figure 3.4-2 illustrates the movement of a single data frame through an open buffer.

### 3.4.2.5 Circular Buffer

Data in a circular (closed) buffer is retained indefinitely. This configuration generally is implemented to produce either periodic waveforms of constant frequency, or one-shot transient waveforms that will be used repeatedly but not necessarily periodically. While closed, the buffer is not accessible from the bus.

In Figure 3.4-3, a single data frame is loaded into the buffer. The buffer is then closed (CIRCULAR BUFFER set HIGH) and clocking is enabled. The data frame subsequently circulates in the buffer while passing data values to the output channels.

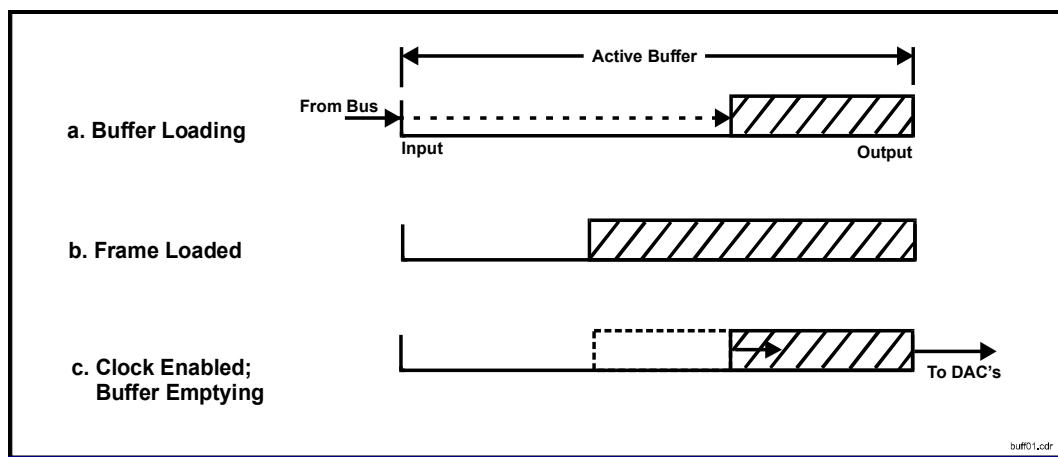

**Figure 3.4-2. Open Buffer Data Flow**

An end-of-frame (EOF) flag accompanies the end-point, or last value in a data frame. The EOF flag is D16 in the buffer, and is set HIGH when the last value in a data frame is loaded. This flag is used during a triggered burst to define the last value in the burst. Multiple contiguous burst functions can reside in the buffer simultaneously.

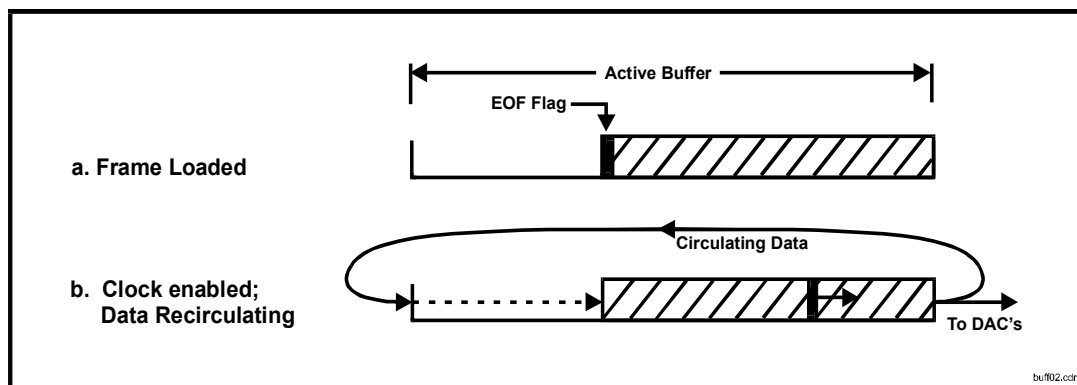

**Figure 3.4-3. Circular Buffer Data Flow**

### 3.4.3 Output Clocking

When the ENABLE CLOCK control bit in the buffer operations register is asserted HIGH, clocking is enabled and the active analog outputs are updated at each occurrence of the sample clock. The sample clock can be generated internally by the rate generator, or can be supplied externally through the I/O connector. Clocking is disabled when the ENABLE CLOCK control bit is LOW.

**NOTE: Refer to Section 3.10 for additional information pertaining to external clocking configurations, and to operation with the adjustable reference frequency.**

Hardware output signal DAC CLOCK OUT (Table 2.2-1) goes LOW momentarily each time a sample clock occurs, Connecting this signal to the CLOCK IO pins of other boards permits synchronous clocking of multiple boards.

#### 3.4.3.1 Clock Source

When buffer operations register bit EXTERNAL CLOCK is HIGH, the sample clock is supplied externally through the I/O connector as CLOCK IO. If the EXTERNAL CLOCK control bit is LOW, the sample clock is derived from the internal rate generator. (See also Section 3.10).

##### 3.4.3.1.1 External Clock

The external clock source can have any frequency up to the maximum value specified for the sampling rate. When the external clock source is selected, sampling occurs on a HIGH-to-LOW transition of the CLOCK IO pin in the I/O connector. When External Clocking is selected, the SW CLOCK control bit in the BOR can be used to generate individual output clocks.

##### 3.4.3.1.2 Internal Rate Generator

The internal rate generator provides a sample clock that is adjustable by the RATE[17..0] control bits in the Sample Rate control register (Table 3.4-7).

**Table 3.4-7. Sample Rate Control Register**  
Offset: 0008h Default: 0000\_0096h

DATA BIT	MODE	DESIGNATION	DESCRIPTION
D00	R/W	RATE 00	Least significant rate bit
D01-D16	R/W	RATE 01 - RATE 16	Intermediate rate bits
D17	R/W	RATE 17	Most significant rate bit
D18-D31	RO	---	Inactive. Returns all-zero.

The sample rate **F<sub>samp</sub>** is calculated from the relationship:

$$F_{\text{samp}} \text{ (Hz)} = 45,000,000 / N_{\text{rate}} ,$$

where **N<sub>rate</sub>** is the decimal equivalent of the value in the RATE value in the Sample Rate control register. Table 3.4-8 illustrates the effect of **N<sub>rate</sub>** on the sample rate. Clocking rates above **450 KSPS** can produce unpredictable results and are not recommended. **N<sub>rate</sub>** can be changed before or during function generation. Refer to Section 3.10 for operation with the adjustable reference frequency.

**Table 3.4-8. Sample Rate Selection**

Nrate ( RATE[15..0] )		SAMPLE RATE Fsamp *
(Dec)	(Hex)	(Samples per Second)
100	00064	450,000
101	00065	445,545
102	00066	441,176
---	---	Fsamp (Hz) = 45,000,000 / Nrate
---	---	
---	---	
262142	3FFFE	171.663
262143	3FFFF	171.662

\* ±0.015 percent.

### 3.4.3.2 Simultaneous Clocking

*Simultaneous sampling* is selected by setting the SIMULTANEOUS OUTPUTS control bit in the board control register HIGH. If simultaneous sampling is selected, the analog values in each successive channel group appear simultaneously at the outputs, with minimum time-skew between channels. Upon each occurrence of the sampling clock, an entire active channel group is transferred from the output buffer, and all outputs are updated simultaneously. In this mode, the effective sample rate for each channel equals the sample rate **Fsamp**.

### 3.4.3.3 Sequential Operation

*Sequential sampling* is selected when the SIMULTANEOUS OUTPUTS control bit in the board control register is LOW. At each clock occurrence in sequential operation, a single channel value is transferred from the buffer to the associated output channel, and the channel is updated immediately. Channel values are read from the buffer beginning with the lowest-numbered active channel in a channel group, and proceeding upward through the highest-numbered active channel. When operating in this mode, the effective sample rate for each channel equals the sample rate **Fsamp** divided by the number of active channels.

## 3.4.4 Sampling Mode

### 3.4.4.1 Continuous Sampling

When the *continuous sampling* mode is selected, data is transferred continuously from the buffer to the analog outputs, assuming that the buffer is not empty and that a sample clock is present. In order for a sample clock to be present, the ENABLE CLOCK control bit in the buffer control register must be HIGH. Continuous sampling is selected when the BURST ENABLED control bit in the board control register is LOW.

#### 3.4.4.2 Data Bursts

During a *triggered burst*, data is transferred continuously from the buffer to the analog outputs until either the **buffer goes empty, or the end-of-frame (EOF) flag is encountered**. In the triggered-burst sampling mode, a software or hardware trigger initiates the transfer of data from the output buffer to the output channels. A software trigger occurs when the BURST TRIGGER control bit in the board control register is set HIGH, whether or not external clocking is selected. The BURST TRIGGER bit remains HIGH during the burst, and clears automatically when the burst is completed.

A hardware burst trigger occurs upon a HIGH-to-LOW transition of the TRIG IN pin of the I/O connector, *if* the BURST ENABLED control bit in the BCR is HIGH, *and* if the BURST READY flag in the BCR also is HIGH. The BURST READY flag is LOW during a burst, and is HIGH if no burst is in progress. (The external trigger input can be disabled by setting the DISABLE EXT BURST TRIG control bit HIGH in the BCR).

Hardware output signal TRIG OUT is LOW during a burst, and is HIGH when the burst is completed. Connecting this signal to the TRIG IN pins of other boards permits synchronous burst triggering of multiple boards.

**NOTE: Polarities of the external TRIG IN and TRIG OUT signals can be inverted individually in software (3.12).**

Multiple burst functions can exist simultaneously within the buffer if the end-of-frame (EOF) flag is used (Paragraph 3.4.1.2). The EOF flag defines the last output value in each data burst. After a burst is triggered, data values from the buffer are clocked to the analog outputs at the selected sample rate until the EOF flag is encountered. The burst then terminates, and clocking of the buffer ceases until a subsequent trigger occurs.

#### 3.4.5 Multiboard Synchronization

Boards that are configured for *synchronous clocking* update their outputs simultaneously in response to a common *clock* signal. Boards that are configured for *synchronous burst triggering* initiate data bursts simultaneously in response to a common *trigger* signal. Multiple boards can be arranged to operate with:

- a. Independent clocking and burst triggering
- b. Synchronous burst triggering (Common burst trigger)
- c. Synchronous clocking (Common DAC clock)
- d. Synchronous clocking and burst triggering (Common trigger and DAC clock).

As many as four boards can be synchronized together. External clock and trigger I/O signaling uses standard TTL levels when the DIFFERENTIAL SYNC I/O control bit is LOW in the BCR, or uses low-voltage differential signaling (LVDS) when the control bit is HIGH.

##### 3.4.5.1 Synchronous Bursts

To **burst-synchronize** a group of boards, the TRIGGER OUT from one board, the *burst-initiator*, is connected to the TRIGGER INP pins of a group of *burst-target* boards. Each burst-target, when operated in the triggered-burst mode (BURST ENABLED set HIGH in the board control register), initiates a single burst from its buffer each time the burst-initiator initiates a burst. The initiator can be configured for either continuous or burst operation.

### 3.4.5.2 Synchronous Clocking

To **clock-synchronize** multiple boards together, the DAC CLOCK OUT from one board, designated the *clock-initiator*, is connected to the CLOCK IO pin of one or *more clock-target* boards. In this case, the clock-targets are configured for external clocking (EXTERNAL CLOCK set HIGH in the buffer control register), and the initiator can be configured for either external or internal clocking.

In addition to generating a DAC CLOCK OUT signal as initiator, the PCIe-16AO16 can operate as a target by receiving a DAC clock through the CLOCK IO pin (Section 3.10).

**NOTE: Refer to Section 3.10 for additional information pertaining to external clocking configurations.**

**NOTE: Polarities of external control signals: TRIG IN, TRIG OUT, DAC CLK OUT, and CLOCK I/O, can be inverted individually in software (3.12).**

### 3.4.6 Function Generation

#### 3.4.6.1 Periodic and One-Shot Functions

*Periodic waveforms* are produced when the buffer is configured for continuous sampling and circular operation. In this mode, the contents of the buffer are scanned continuously as long as clocking is enabled and a clock is present. The data frame is recirculated through the buffer repeatedly. Clocking is enabled when the ENABLE CLOCK control bit in the buffer operations register is HIGH.

If triggered-burst sampling is used in conjunction with a circular buffer, a *one-shot waveform* is produced that contains all values within a single data frame. The triggered burst is initiated by a software or hardware trigger, and terminates automatically when the end-of-frame (EOF) flag is encountered. Because the buffer is circular, the waveform is retained in the buffer and can be reproduced repeatedly by subsequent triggers.

#### 3.4.6.2 Multiple Functions

When multiple functions are loaded into the buffer as contiguous data frames, and if triggered-burst sampling is selected, the functions will be generated sequentially in response to a series of burst triggers. If the buffer is open, the functions will be flushed from the buffer as they are clocked to the analog outputs. However, if the buffer is closed (circular), the functions will be retained in the buffer, and the series of functions will be repeated indefinitely. .

#### 3.4.6.3 Function Sequencing

A new function (data frame) can be concatenated to the end of an existing function in a circular buffer, while the existing function is being flushed from the buffer. During this operation, the existing function is flushed from the buffer as it is clocked to the outputs, and is replaced by the new function. When the last value of the existing function is clocked out of the buffer, the buffer closes and the new function seamlessly begins circulating in the buffer and producing an output.

The introduction of the new function commences by setting the LOAD REQUEST flag HIGH in the buffer operations register, and by then waiting for the LOAD READY flag to be asserted. (In effect, LOAD REQUEST is an "interrupt request" to the buffer). The LOAD READY flag indicates that the buffer has opened, and that the existing function is being flushed from the buffer, beginning with the first value in the function's data frame. Assertion of LOAD READY is selectable as an interrupt event (Section 3.6).

After LOAD READY goes HIGH, the new function is written to the buffer and is terminated with an EOF flag (data bit D16 set HIGH). The EOF flag of the existing function causes the buffer to close, and clears both the LOAD READY flag and the LOAD REQUEST control bit. Notice that the loading of the new function into the buffer must be completed before the existing function terminates. The HIGH-to-LOW transition of LOAD READY also is selectable as an interrupt event.

In Figure 3.4-4, an existing function is replaced by a new function while the existing ('old') function is flushed from the buffer.

NOTE: If the loading of a new function extends beyond the LOAD-READY interval, the FRAME OVERFLOW flag is set HIGH in the Buffer Operations register, indicating data loss. Once set, this flag remains HIGH until written LOW directly from the bus, or by initialization

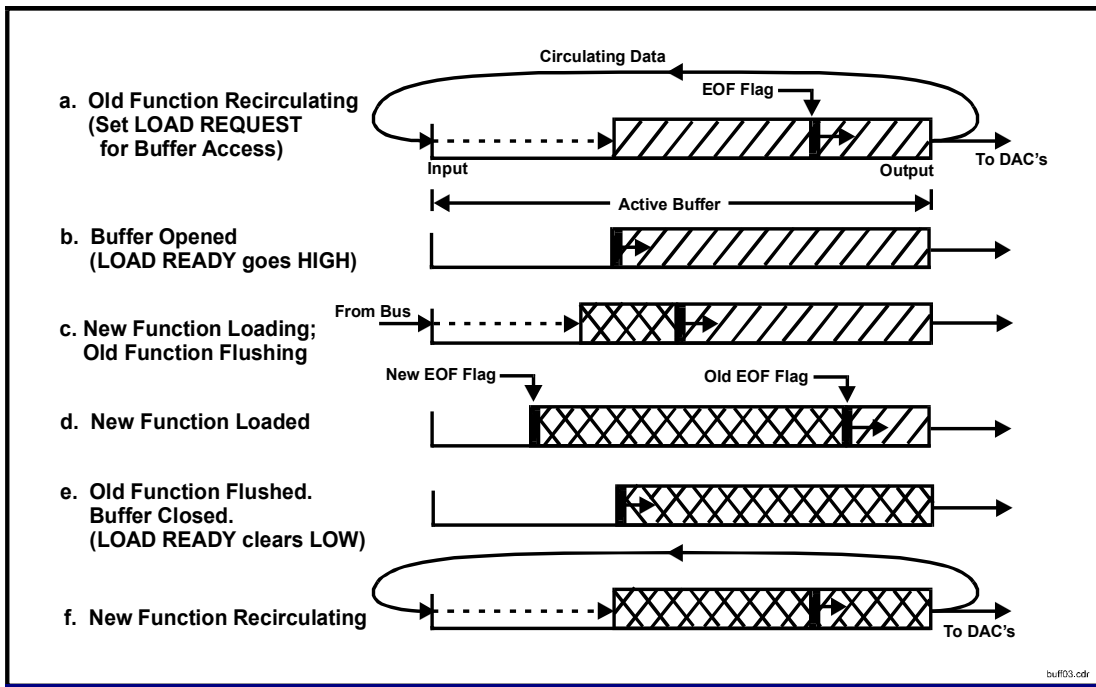

Figure 3.4-4. Function Sequencing

### 3.5 Autocalibration

Autocalibration is invoked setting the AUTOCALIBRATION control bit HIGH in the BCR. The control bit returns LOW when autocalibration is completed.

Autocalibration has a maximum duration of approximately five seconds. Completion of the operation can be detected either by polling the AUTOCALIBRATION control bit for a zero-state, or by selecting the 'Autocalibration completed' interrupt event (Section 3.6) and waiting for the interrupt request. Write-accesses from the PCI bus should be avoided during autocalibration, and the board should be initialized after autocalibration is completed.

**NOTE: The analog outputs are active during autocalibration, and fluctuate between midrange (zero-level) and positive fullscale.**

To compensate for component aging, and to minimize the effects of temperature on accuracy, the autocalibration function determines the optimum calibration values for current conditions. Autocalibration can be invoked at any time, but should not be implemented while the system is experiencing a major environmental transition such as that which usually occurs immediately after power is applied.

Calibration correction values are retained until a PCI reset occurs or until autocalibration is repeated. If a board is defective, the autocalibration process may be unable to successfully calibrate all output channels. If this situation occurs, the AUTOCAL STATUS FLAG bit in the BCR will be set HIGH at the end of the autocalibration interval, and will remain HIGH until a subsequent initialization or autocalibration occurs. The AUTOCAL-STATUS FLAG remains LOW unless an autocalibration failure occurs.

**NOTE: To ensure maximum output accuracy, autocalibration should be performed after a new output range is selected.**

### 3.6 Interrupt Control

In order for the board to generate a PCI interrupt, *both* of the following conditions must occur:

- a. The internal controller must generate a Local Interrupt Request
- b. The *PCIe interrupt* must be enabled.

If the internal controller generates a local interrupt request, a PCI bus interrupt will not occur unless the PCI interrupt has been enabled as described in Paragraph 3.6.2.

#### 3.6.1 Local Interrupt Request

The single local interrupt request line is controlled by the INTERRUPT A[2:0] and INTERRUPT REQUEST FLAG control bits in the BCR. The source condition for the request is selected as shown in Table 3.6.1-1. When the selected condition occurs, a local interrupt request is generated and the INTERRUPT REQUEST FLAG bit is set in the BCR. The request remains asserted until either (a) the PCI bus clears the BCR request flag, or (b) the associated interrupt condition is deasserted. A local interrupt request is generated automatically at the end of initialization.

**Table 3.6-1. Interrupt Event Selection**

**BCR Bits D10..D08**

**Default: 0000\_0000h**

<b>INTERRUPT A[2:0]</b>	<b>INTERRUPT CONDITION</b>
0	Idle. Interrupt disabled unless initializing. Default state.
1	Autocalibration completed
2	Output buffer empty
3	Output buffer low-quarter (buffer less than 1/4-full)
4	Output buffer high-quarter (buffer 3/4-full)
5	Burst Trigger Ready
6	Load Ready (LOW-to-HIGH transition)
7	End Load Ready (HIGH-to-LOW transition of Load Ready)

Detection of an interrupt condition or event is *edge-sensitive*. An interrupt request is generated if, and only if, a specific interrupt condition undergoes a *transition* from 'false' (not-true) to 'true' while that condition is selected.

### 3.6.2 Enabling the PCIe Interrupt

A local interrupt request will not produce an interrupt on the PCI Express bus unless the PCI Express interrupt is enabled. Refer to the PLX PCI-9056 reference manual for information pertaining to the handling of interrupts.

### 3.7 Remote Ground Sensing

Remote ground sensing for single-ended outputs is enabled when the REMOTE GROUND SENSE control bit in the BCR is HIGH, and is disabled when the control bit is LOW. Unless specific wiring provisions have been made to implement remote sensing, the remote sense control bit should be left in the default (LOW) disabled state.

**NOTE: Differences between ground potentials do not significantly affect the integrity of differential signals, and introducing a ground-sense correction signal will actually degrade accuracy. For this reason, remote ground sensing is disabled for differential outputs.**

### 3.8 Application Examples

Specific operating modes and procedures will vary widely according to the unique requirements of each application. The examples presented in this section (Table 3.8-1) illustrate several basic operating modes, and can be modified or combined for more complex operations.

References to *functions* in these examples generally apply to a single output channel, for simplicity of explanation. However, it must be remembered that each active channel represents an independent set of functional values and that all channels share a common sample clock.

**Table 3.8-1. Summary of Operation Examples**

Operation Example	Description
Sequential Direct Outputs	Each value written to the output data buffer updates the associated analog output channel when clocked, independently of the other channels.
Simultaneous Direct Outputs	Data values accumulate in the output data buffer until an entire channel group has been loaded. When the last channel is loaded, all active output channels update simultaneously when clocked.
Continuous Function	Identical to Simultaneous Direct Outputs, except: <ol style="list-style-type: none"> <li>a. A clocking rate other than the maximum rate may be selected.</li> <li>b. The buffer is not allowed to become either empty or full.</li> </ol>
Periodic Function	A single function is generated repeatedly in each active channel.
Function Burst	One or more functions are generated as discrete data bursts. The burst cycle is repeated indefinitely if the circular-buffer mode is selected.
Function Sequencing	An existing active function n is replaced seamlessly by a new function.

Each of the examples in this section assumes that the initial operations listed in Table 3.8-2 have already been performed.

**Table 3.8-2. Initial Operations**

Operation	Default Value	Applicable Paragraph
The board has been reset or initialized.	---	3.3
The active channel group has been defined .	All channels active	3.4.1.1
The required output coding has been selected.	Offset binary	3.4.1.3.2
Active buffer size has been selected.	Maximum buffer size	3.4.2.2
Remote ground sensing has been selected or deselected.	Deselected	3.7

The remaining operational parameters are assumed to be in the following *default* states:

Buffer mode:	Open	Sample rate:	Maximum
Buffer status:	Empty	Sampling mode:	Sequential
Clock source:	Internal (BOR)	Interrupt selected:	0 (Idle)
Clock status:	Disabled (BOR)		

### 3.8.1 Sequential Direct Outputs

**Table 3.8-3. Sequential Direct Outputs Example**

Operation	PCI Bus Action	Board Response
Enable clocking	Set the ENABLE CLOCK control bit HIGH in the buffer operations register.	Clocking is enabled at the default rate.
Load the output value for the first active channel.	Write the first value to the output data buffer.	Output value appears immediately (when clocked) at the analog output.
Load the output values for the remaining active channels.	Write the remaining active channel values to the output data buffer.	Remaining active analog outputs are updated in ascending sequence.
Repeat the above operations for subsequent channel groups.	Continue to write output values to the output data buffer.	Each value written to the buffer is transferred immediately to the associated analog output when clocked

- Notes:
1. End-of-frame (EOF) flags are ignored when operating in the open-buffer mode. Only D15..0 are active in the output buffer.
  2. Data written to the buffer at rates above 450KSPS will accumulate in the buffer.
  3. Access to an individual output channel is accomplished by first selecting (enabling) only the specific channel, and by then writing the output value to the buffer.

### 3.8.2 Simultaneous Direct Outputs

**Table 3.8-4. Simultaneous Direct (Single Group) Outputs Example**

Operation	PCI Bus Action	Board Response
Select simultaneous clocking.	Set SIMULTANEOUS OUTPUTS in the board control register located at 00h.	Simultaneous clocking is enabled.
Enable clocking	Set ENABLE CLOCK in the buffer operations register.	Clocking is enabled at the maximum rate.
Load the output value for the first active channel.	Write the first value to the output data buffer.	First value is retained in the buffer.
Load the output values for the remaining active channels.	Write the remaining active channel values to the output data buffer.	Remaining values are accumulated in the buffer. When the last value is loaded, all values are extracted from the buffer and appear simultaneously at the associated output channels.
Repeat the above operations for subsequent channel groups.	Continue to write output values to the output data buffer.	All active channels are updated simultaneously when the last value in each group is written to the buffer.

- Notes:
1. End-of-frame (EOF) flags are ignored when operating with in the open-buffer mode. Only D15..0 are active in the output buffer.
  2. Data written to the buffer at rates above 480KSPS will accumulate in the buffer.

### 3.8.3 Continuous Function

**Table 3.8-5. Continuous Function Example**

Operation	PCI Bus Action	Board Response
Select simultaneous clocking.	Set SIMULTANEOUS OUTPUTS in the board control register.	Simultaneous clocking is enabled.
If the internal rate generator is to be used, select the sample rate. (Skip this step if external clocking will be used).	Write the required sample clocking rate to the sample rate control register at 08h.	The frequency of the internal rate generator is selected, if internal clocking is required.
Note: The following two operations may be performed simultaneously with a single write-transaction to the buffer operations register:	---	---
If external clocking is required, select external clocking.	To select external clocking, set EXTERNAL CLOCK in the buffer operations register.	External clocking is selected, if required.
Enable clocking	Set ENABLE CLOCK in the buffer operations register.	Clocking is enabled.
Select the buffer lo-quarter interrupt.	Set the INT[] bit field to 3 in the board control register.	The interrupt will respond when the buffer becomes less than 1/4 full.
Write a block of values to all active channels. Total block size should be between 1/4 and 3/4 of the buffer size. (Note 1).  To avoid discontinuities in the output functions, the loading rate for channel groups must be greater than the sample (clocking) rate times the number of active channels. Maximum loading rate is 15MSPS during DMA transfers.	Write function values for all active channels to the output data buffer.	All active channels produce their respective output functions.
Wait for the lo-quarter interrupt. (Note 2).	Other, unrelated activities can occur on the PCI bus until the lo-quarter interrupt request occurs.	The output buffer empties to less than 1/4-full status.
Repeat the previous two steps to sustain function generation.		All output functions proceed continuously.

**Notes:**

1. The size of a data block must be at least 1/4 the size of the buffer to ensure that the lo-quarter interrupt will occur. Also, the block size must be no greater than 3/4 the size of the buffer to avoid data loss by forcing the buffer to full-status.
2. Response to the interrupt must be fast enough to prevent the buffer from going empty.

### 3.8.4 Periodic Function

**Table 3.8-6. Periodic Function Example**

Operation	PCI Bus Action	Board Response
Select simultaneous clocking.	Set SIMULTANEOUS OUTPUTS in the board control register located at 00h.	Simultaneous clocking is enabled.
Load the first function value for each active channel.	Write the values for the first active group to the output data buffer.	Initial values for all active channels accumulate in the buffer.
Load the remaining function values for all active channels.  Set the end-of-frame (EOF) flag.	Write all remaining function values for all active channels to the output buffer.  Set the EOF flag (D16 in the output buffer) HIGH when writing the data value for the last channel in the last group.	All function values for all active channels accumulate in the buffer.  The EOF flag is set HIGH in the buffer location that contains the last channel value in the last channel group.
If the internal rate generator is to be used, select the sample rate. (Skip this step if external clocking is required).	Write the required sample rate to the sample rate control register.	The frequency of the internal rate generator is selected if internal clocking is required.
Note: The remaining operations may be performed simultaneously with a single write-transaction to the buffer operations register:	---	---
Select the circular buffer mode.	Set CIRCULAR BUFFER in the buffer operations register.	The output buffer is closed (circular).
If external clocking is required, select external clocking.	To select external clocking, set EXTERNAL CLOCK in the buffer operations register.	External clocking is selected, if required.
Enable the sample clock.	Set ENABLE CLOCK in the buffer operations register.	Clocking is enabled. All active channels produce their respective functions repeatedly until the clock is disabled or the operating mode is changed. All outputs update simultaneously at the sample clock rate.

**Notes:**

1. To generate periodic functions simultaneously in multiple channels, all functions must be commensurate. That is, the functions in all channels must have frequencies that are exact integer multiples of the frequency of the lowest-frequency channel. Conversely, the period of the lowest-frequency channel must be an exact integer multiple of the period of each of the other channels.

### 3.8.5 Function Burst

**Table 3.8-7. Function Burst Example**

Operation	PCI Bus Action	Board Response
Clear the data buffer and disable clocking.	Set CLEAR BUFFER) and clear ENABLE CLOCK in the buffer operations Register.	The buffer is cleared and clocking is disabled.
Select simultaneous clocking.	Set SIMULTANEOUS OUTPUTS in the board control register.	Simultaneous clocking is selected.
Load the first function value for each active channel.	Write the values for the first active group to the output data buffer.	Initial values for all active channels accumulate in the buffer.
Load the remaining function values for all active channels.	Write all remaining function values for all active channels to the output buffer.	All function values for all active channels accumulate in the buffer.
Set the end-of-frame (EOF) flag.	Set the EOF flag (D16 in the output buffer) HIGH when writing the data value for the last channel in the last group.	The EOF flag is set HIGH in the buffer location that contains the last channel value in the last channel group.
If more than one burst-function is required, repeat the previous operations for each additional function.	---	If required, additional burst functions accumulate in the output buffer.
If the internal rate generator is to be used, select the sample rate.	Write the required sample rate to the sample rate control register at 08h.	The frequency of the internal rate generator is selected if internal clocking is required.
Select triggered-burst mode.	Set BURST ENABLED in the board control register.	The triggered-burst sampling mode is selected.
Prepare the buffer operations register for burst mode:	Write a single value to the buffer operations register:	---
If the burst functions will be used repeatedly, select the circular buffer mode.	To select the circular buffer mode, set CIRCULAR BUFFER.	If required, the output buffer is closed (circular), and all functions will be retained in the buffer indefinitely.
If external clocking is required, select external clocking.	To select external clocking, set EXTERNAL CLOCK.	External clocking is selected, if required.
Enable the sample clock.	Set ENABLE CLOCK.	Clocking is enabled. The board is awaiting a burst trigger.
For software burst triggering, generate a software trigger to produce a single burst on all active output channels.	Set BURST TRIGGER in the board control register. (BURST TRIGGER is cleared automatically when the burst is completed).	All active output channels produce a single burst in response to a software trigger. (Use Interrupt-5 to detect the burst-ready condition).
For external burst triggering, no further bus activity is required.	---	All active output channels produce a single burst in response to each HIGH-to-LOW transition of TRIGGER INPUT at the I/O connector.

### 3.8.6 Function Sequencing

**Table 3.8-8. Function Sequencing Example**

Operation	PCI Bus Action	Board Response
<p>Establish a periodic function as described in Paragraph 3.8.4.</p> <p>The following operations will replace the original ('old') function in each channel with a new function.</p>	---	<p>Each active output is producing a specific output function or waveform. The output buffer is circular (closed), and is not accessible from the bus.</p>
<p>Request access to the output data buffer.</p>	<p>Select the load-ready interrupt by setting INTERRUPT A[] =6 in the board control register.</p> <p>Set LOAD REQUEST in the buffer operations register.</p>	<p>The load-ready interrupt is selected.</p> <p>The board will assert the LOAD READY flag when the EOF flag in the original function occurs.</p>
<p>Wait for the buffer to open.</p>	<p>Wait for the load-ready interrupt request. Then clear the INTERRUPT A[2..0] and INTERRUPT REQUEST FLAG fields in the board control register.</p>	<p>The EOF flag in the existing function set causes the LOAD READY bit in the buffer operations register to be asserted. A load-ready interrupt request is generated.</p> <p>The buffer is now open, and the original functions are being flushed from the buffer.</p>
<p>Load the new function for each active channel into the buffer. Set the end-of-frame (EOF) flag.</p>	<p>Write the function values for all active channels to the output buffer. Set the EOF flag (D16 in the output buffer) HIGH when writing the data value for the last channel in the last group.</p>	<p>New function values for all active channels reside in the buffer. The EOF flag is set HIGH in the buffer location that contains the last channel value in the last channel group.</p> <p>The original functions are still active, and the remaining values are flushed from the buffer as they are sent to the output channels.</p>
<p>(None required)</p>	<p>No further attention is required from the PCI bus.</p>	<p>The buffer returns to circular (closed) mode when the last data value in the original function set moves out of the buffer. The new function then commences seamlessly and circulates within the buffer.</p> <p>Both the Load Request control bit and the Load Ready flag are cleared automatically when the buffer closes.</p> <p>The End Load Ready interrupt condition can be used to detect completion of the flushing sequence.</p>

### 3.9 Buffer DMA Operation

DMA transfers to the analog output FIFO buffer are supported in either **block-mode** or **demand-mode**, with the board operating as bus master. Demand mode operation requires the **slow terminate** mode. Refer to the PEX-8311 reference manual for a detailed description of the associated DMA configuration registers.

### 3.10 Synchronization with Sigma-Delta Input Products

Section 3.4 describes the synchronization of multiple 16AO12/16AO20 boards using the trigger I/O and DAC clock output pins in the system I/O connector. In addition to these functions, an adjustable high-frequency reference is available at the CLOCK IO pin (Table 2.2-1) for synchronizing the PCIe-16AO16 with sigma-delta and delta-sigma analog input boards such as the PMC-6SDI or PCI-16SDI. The PCIe-16AO16 can be operated as either a target or an initiator in systems that include one or more GSC sigma-delta products.

To support the synchronization of multiple boards to a single reference frequency, all GSC sigma-delta boards can be configured to accept an external high-frequency source as an input to their internal sample-rate dividers. Clocking requirements for specific each sigma-delta products are described in the associated reference manuals.

#### 3.10.1 Adjustable Reference Frequency Control

The adjustable reference frequency is adjustable from 16MHz to 32MHz, with 0.2 percent resolution, and is controlled by the Adjustable Reference Frequency control register shown in Table 3.10-1.

**Table 3.10-1. Adjustable Reference Frequency Control Register**  
**Offset: 0000 001Ch** **Default: 0000 0000h**

BIT FIELD	ACCESS MODE	DESIGNATION	DESCRIPTION
D[08:00]	R/W	CLOCK RATE ( <b>Nclk</b> )	Controls the frequency of the adjustable clock..
D[09]	R/W	SELECT ALTERNATE REFERENCE	Selects an alternate frequency source for the clocking rate generator (Table 3.10-2).
D[31:10]	RO	(Reserved, read-only)	(Inactive)

The frequency **Fadj-ref** of the adjustable clock is controlled by the 9-bit value **Nclk** according to the relationship:

$$\mathbf{Fadj-ref} = 16 * ( 1 + \mathbf{Nclk} / 511 ),$$

where **Fadj-ref** is in Megahertz, and **Nclk** is an integer with a value from zero to 511. For example, a decimal value of 100 for **Nclk** would produce a clock frequency of 19.13MHz.

This expression is based upon a master clock frequency of 45.000MHz. For other master clock frequencies **Fclk**, use the expression:

$$\mathbf{Fadj-ref} = (\mathbf{Fclk} / 45\text{MHz}) * 16 * ( 1 + \mathbf{Nclk} / 511 ). \quad (\mathbf{Fclk} \text{ in MHz})$$

**Note:** When the PCIe-16AO16 is operating from the adjustable reference, the frequency **Fadj-ref** replaces the 45MHz master clock used to determine the internal rate generator frequency described in Section 3.4.3. Consequently, the formula for the sample rate **Fsamp** shown in Section 3.4.3.1.2 becomes:

$$\mathbf{Fsamp} \text{ (Hz)} = \mathbf{Fadj-ref} / \mathbf{Nrate},$$

where **Fadj-ref** is the frequency of the adjustable reference, *in Hertz*, and **Nrate** is an 18-bit integer in the Sample Rate control register.

If external clocking is selected, any modification of **Nclk** invokes an automatic settling delay of approximately 100 milliseconds, during which the CLOCK READY status bit is held LOW in the buffer Operations register.

### 3.10.2 Initiator/Target Configurations

The function of the CLOCK IO signal in the system I/O connector (Table 2.2-1) is controlled by the SELECT ALTERNATE REFERENCE control bit in the Adjustable Reference Frequency control register, and the EXTERNAL CLOCK control bit in the Buffer Operations control register. Table 3.10-2 summarizes the available clocking configurations that use the CLOCK-IO signal.

In *all* configurations, the DAC CLOCK OUT signal at the I/O connector is the analog output sampling clock for the board, and produces a single clock pulse each time the local outputs are updated. Likewise, the TRIG OUT pin *always* produces a single burst trigger pulse each time a burst is initiated.

**Table 3.10-2. Multiboard Clocking Configurations**

SELECT ALTERNATE REFERENCE	EXTERNAL CLOCK (BOR)	CLOCK I/O PIN FUNCTION		LOCAL RESPONSE	TYPICAL APPLICATIONS
		DIRECTION *	FUNCTION		
0	0	Output	45MHz Master Clock	INITIATOR: Internal rate generator operates from the 45MHz master clock.	Synchronize external targets to the local master clock.
1	0	Output	Adj Ref	INITIATOR: Internal rate generator operates from the adjustable reference frequency.	Synchronize external targets to the local adjustable reference.
0	1	Input	DAC Clock	TARGET: Outputs update directly from the external DAC clock.	Clock local outputs from an external initiator.
1	1	Input	Ext Ref	TARGET: Internal rate generator operates from the external reference frequency.	Synchronize local rate generator clocking to an external initiator.

\* See Section 3.13 for control outputs isolation provisions.

**NOTE: Polarities of external control signals: TRIG IN, TRIG OUT, DAC CLK OUT, and CLOCK I/O can be inverted individually in software (3.12).**



### **3.13 Isolating the System Control Output Pins:**

(Firmware Revision 011 and higher)

To eliminate activity on the following external system control pin pairs (Table 2.2-1) when they are not required for system control functions, these three pairs can be configured as passive outputs through the BCR.

TRIG OUT,  
DAC CLK OUT,  
CLOCK I/O,

Each of these three pin pairs is controlled by a dedicated control bit in the BOR (Buffer Operations register), Table 3.4-5:

ISOLATE TRIG OUT,  
ISOLATE DAC CLOCK OUT,  
ISOLATE CLOCK IO.

When each of these control bits is asserted HIGH in the BOR, the corresponding pin set becomes a logic-LOW output. Standard precautions pertaining to logic level conflicts should be applied if these pins are connected to other boards.

## SECTION 4.0

### PRINCIPLES OF OPERATION

#### 4.1 General Description

The PCIe-16AO16 board contains sixteen 16-bit D/A converters (DAC's), and all supporting functions necessary for adding precision high-speed analog output capability to a PCIe application. As Figure 4.1-1 illustrates, a PCI interface adapter provides the interface between the controlling PCI bus and an internal local controller. The local controller performs all internal configuration and data manipulation functions, including autocalibration.

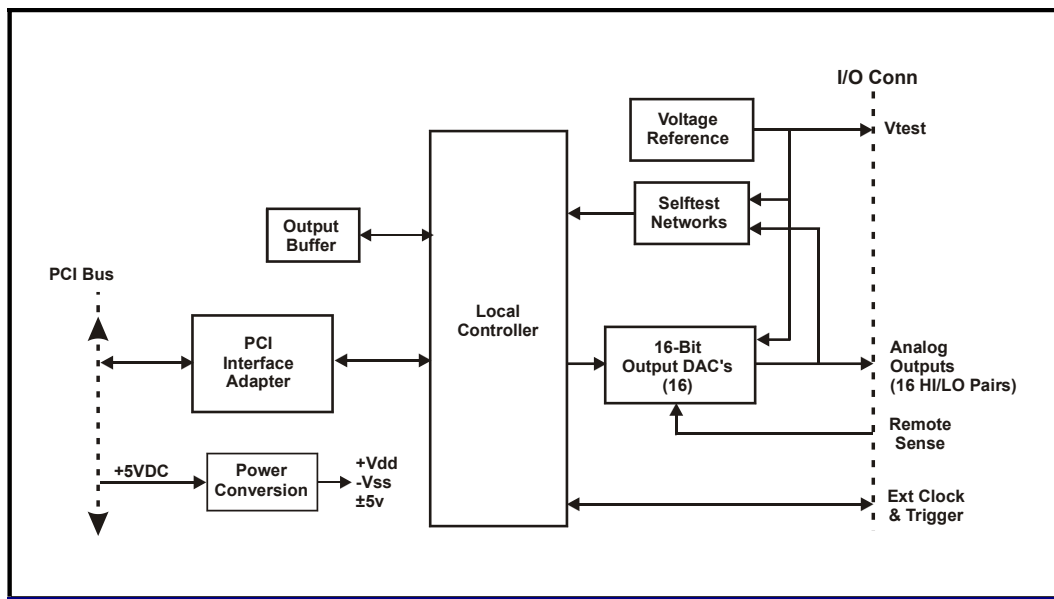

**Figure 4.1-1. Functional Block Diagram**

During normal operation, analog output data values are written from the PCI bus to the output buffer. The data values subsequently are serialized and transferred to the respective analog output DAC's. Remote sensing of remote ground potentials is software selectable and affects all outputs simultaneously.

External control inputs and outputs accept burst-trigger and sample-clock inputs, and provide the digital signals necessary for multiboard synchronization.

Selftest networks allow the controller to compare the analog levels from all output channels against the internal voltage reference, and are used to establish the internal connections necessary during autocalibration. All channels are calibrated with respect to a single precision voltage reference, which is available for verification at the system I/O connector.

Offset and gain corrections for each output channel are determined during on-demand autocalibration, and are used to cancel offset and gain errors in the channel. Autocalibration provides the adjustment functions that otherwise would be associated with 32 manual trimmers in conventional analog configurations. Calibration control values are determined and stored in calibration DAC's during autocalibration, and are retained until the PCI bus is reset or autocalibration is executed again.

## **4.2 Analog Outputs**

Each of the sixteen analog output channels consists of a 16-bit output DAC and an output buffer amplifier. The local controller reads the 16-bit channel data value for each channel from the analog output buffer, and sends the value serially to the associated output DAC. The output DAC deserializes the data to obtain the original 16-bit data word, and holds that word in an internal buffer until commanded to transfer the data to the output register that drives the DAC output.

All output registers are updated simultaneously if the controlling software has selected simultaneous sampling, or in ascending channel sequence if sequential sampling is selected. Output ranges are software-selected as  $\pm 1.25V$ ,  $\pm 2.5V$ ,  $\pm 5V$  or  $\pm 10V$ .

## **4.3 Autocalibration**

Autocalibration is an embedded firmware utility that calibrates all output channels to a single internal voltage reference. The utility can be invoked at any time by the control software.

An internal voltage reference is adjusted during the calibration procedure described in Section 2 to equal 99.9 percent of the maximum output voltage range. This voltage reference is compared with actual channel output values to calibrate the gain of each analog output channel. Calibration values for channels offsets are determined by comparing channel outputs with the potential on the internal analog ground bus.

Each offset and gain correction value is adjusted in a successive approximation sequence that commences with the value in an all-zero state. The most significant bit initially is set to "1", and the resulting effect on the channel is measured. Depending upon the measured response, the bit either is cleared or is left in the "1" state. The next lower significant bit is then tested in the same manner, and this process continues until all active bits in the correction value have been tested and adjusted. The final value is stored in volatile calibration memory, and is retained until a PCI reset occurs or until autocalibration is executed again.

## **4.4 Power Control**

Well-regulated and noise-free supply voltages of +5 Volts and  $\pm 14$  Volts are required by the analog networks, and are derived from the PCI Bus +5-Volt input through a DC/DC converter. To obtain optimum regulation and minimum noise from the internal supplies, all analog power voltages employ linear postregulation.

**APPENDIX A**

**LOCAL REGISTER QUICK REFERENCE**

## APPENDIX A LOCAL REGISTER QUICK REFERENCE

This appendix summarizes all local registers and principal control-bit fields that appear in Section 3.

**Table 3.1-1. Control and Data Registers**

Offset	Register	Mode*	Default	Primary Function
00	BOARD CONTROL (BCR)	R/W	0000_0810h	Board Control Register (BCR)
04	CHANNEL SELECTION	R/W	0000_FFFFh	Channel-enabling mask
08	SAMPLE RATE	R/W	0000_0096h	Analog output clocking rate selection
0C	BUFFER OPERATIONS	R/W	0000_340Fh	Buffer size selection and status flags
10	ASSEMBLY CONFIGURATION **	RO	00XX_XXXXh	Firmware revision and hardware options
14	Autocal Values **	R/W	0000_0XXXh	---
18	OUTPUT DATA BUFFER	WO	0000_0000h	Analog output FIFO buffer
1C	ADJUSTABLE CLOCK	R/W	0000_0000h	Control of the adjustable clock generator.

\* R/W = Read/Write; RO = Read-only; WO = Write-only .

\*\* Maintenance register; shown for reference.

**Table 3.2-1. Board Control Register**

**Offset: 0000h**

**Default: 0000\_0810h**

Bit	Mode	Designation	Def	Description	Ref
D00	R/W	BURST ENABLED	0	Selects burst-mode if HIGH, continuous-mode if LOW.	3.4.4, 3.4.5
D01	RO	BURST READY	0	If HIGH, indicates that a burst trigger will be accepted. If LOW, indicates that a burst is in progress, and that a trigger will not be accepted. Available as an interrupt condition.	
D02	R/W	*BURST TRIGGER	0	Software burst trigger, asserted HIGH. Active only when BURST ENABLED control bit is asserted.	
D03	R/W	REMOTE GROUND SENSE	0	Correction is made for remote ground potentials when this bit is HIGH.	3.7
D04	R/W	OFFSET BINARY	1	Selects offset-binary data format when asserted HIGH, or two's complement when LOW.	3.4.1.3
D05	R/W	DIFFERENTIAL SYNC I/O	0	Selects differential (LVDS) external clock and trigger I/O when high, or TTL clock and trigger I/O when low.	3.4.5
D06	R/W	DISABLE EXT BURST TRIG	0	Disables external burst trigger input.	3.4.4.2
D07	R/W	SIMULTANEOUS OUTPUTS	0	When HIGH, selects simultaneous output clocking. When LOW, selects sequential clocking. Default is LOW; i.e.: sequential clocking.	3.4.3.2, 3.4.3.3
D08-D10	R/W	INTERRUPT A0-A2	0	Interrupt event selection.	3.6
D11	R/W	INTERRUPT REQUEST FLAG	1	Set HIGH when the board asserts an interrupt request. Clears the request when cleared LOW by the bus.	
D12	R/W	(Reserved)	0	---	---
D13	R/W	AUTOCALIBRATION <sup>1</sup>	0	Initiates autocalibration. Completion is available as an interrupt condition.	3.5
D14	RO	AUTOCAL STATUS FLAG	0	Records the status of autocalibration; LOW for pass, HIGH for fail.	
D15	R/W	INITIALIZE <sup>1</sup>	0	Initializes the board when set HIGH. Sets all defaults for all registers.	3.3.2
D16-D17	R/W	OUTPUT RANGE	0	Selects the output voltage range as: 0 => ±1.25V, or (Reserved) * 1 => ±2.5V, or ±5V * 2 => ±5V, or ±10V * 3 => ±10V, or ±20V * * With the High-Level Differential outputs option.	3.4.1.4
D18	R/W	INVERT TRIGGER INPUT	0	Inverts the external TRIG IN signal	3.12
D19	R/W	INVERT TRIGGER OUTPUT	0	Inverts the external TRIG OUT signal	
D20	R/W	INVERT DAC CLOCK OUT	0	Inverts the external DAC CLK OUT signal	
D21	R/W	INVERT CLOCK I/O	0	Inverts the external CLOCK I/O in/out signals	
D22	R/W	WATCHDOG BIT ENABLE	0	Replaces the normal Trigger output at the TRIG OUT HI/LO pins with the WATCHDOG OUTPUT control bit.	(FW-003B Only)
D23	R/W	WATCHDOG OUTPUT	0	Watchdog monitor control bit. Available as TRIG OUT HI/LO in the system I/O connector.	
D24-D31	RO	(Reserved)	0	Inactive. Returns all-zero.	---

<sup>1</sup> Cleared automatically when operation is completed.

R/W = Read/Write; RO=Read-Only.

**Table 3.4-2. Channel Selection Register**

Offset: 0004h

Default: 0000\_FFFFh

BIT	MODE	DESIGNATION	DESCRIPTION
D00	R/W	ENABLE CHANNEL 00	Channel-Enable mask. A channel is enabled if the associated mask bit is HIGH, or is disabled if the bit is LOW.
D01	R/W	ENABLE CHANNEL 01	
D02	R/W	ENABLE CHANNEL 02	
D03	R/W	ENABLE CHANNEL 03	
D04-D15	R/W	ENABLE CHANNEL 04-15	
D16-D32	RO	(Reserved)	Inactive. Returns all-zero.

**Table 3.4-3. Output Data Buffer**

Offset: 0018h

Default: N/A (Write-Only)

BIT	MODE*	DESIGNATION	DESCRIPTION
D00	WO	DATA 00	Least significant data bit
D01-D14	WO	DATA 01 - DATA 14	Intermediate data bits
D15	WO	DATA 15	Most significant data bit
D16	WO	EOF FLAG	End-of-frame (EOF) flag.
D17-D31	WO	---	(Inactive)

\* WO indicates write-only access. Read-access returns all-zero value.

**Table 3.4-4. Output Data Coding; D15..D00**

ANALOG OUTPUT LEVEL	DIGITAL VALUE (Hex)	
	OFFSET BINARY	TWO'S COMPLEMENT
Positive Full Scale minus 1 LSB	XXXX FFFF	XXXX 7FFF
Zero plus 1 LSB	XXXX 8001	XXXX 0001
Zero	XXXX 8000	XXXX 0000
Zero minus 1 LSB	XXXX 7FFF	XXXX FFFF
Negative Full Scale plus 1 LSB	XXXX 0001	XXXX 8001
Negative Full Scale	XXXX 0000	XXXX 8000

**Table 3.4-5. Buffer Operations Register**

Offset: 000Ch

Default: 0000\_340Fh

Bit	Mode	Designation	Def	Description	Ref
D00-D03	R/W	SIZE 00-SIZE 03	Fh	Size-selection bit field for the active buffer. Defaults to 256K Samples.	3.4.2.2
D04	R/W	EXTERNAL CLOCK	0	Selects hardware or software clock source when HIGH, or the internal rate generator when LOW. Default is LOW (internal rate generator).	3.4.3.1.1
D05	R/W	ENABLE CLOCK	0	Enables output clocking when HIGH. Disables clocking when LOW. Default is LOW (clocking disabled).	3.4.3
D06	RO	CLOCK READY	0	If external clocking is selected, indicates when HIGH that a hardware or software clock will be accepted. If LOW, indicates that the output is not ready to accept a clock. Active only when external clocking is selected.	3.10.1
D07	R/W	* SW CLOCK	0	If external clocking is selected, produces a single output clock event when asserted. Clears LOW automatically when the clock event is completed. Active only when external clocking is selected.	3.4.3.1.1
D08	R/W	CIRCULAR BUFFER	0	Selects circular buffer configuration if HIGH, or open self-flushing buffer configuration if LOW. Access for loading new data into the circular buffer must be requested by asserting LOAD REQUEST. Default is LOW; i.e. open buffer.	3.4.2.5
D09	R/W	* LOAD REQUEST	0	When set HIGH, requests loading access to the circular buffer. Initializes LOW.	3.4.6.3
D10	RO	LOAD READY	1	Set HIGH when the frame index passes through zero, if both CIRCULAR BUFFER and LOAD REQUEST are HIGH. When HIGH, indicates that the circular buffer is ready to accept new data. Available as an interrupt condition. Defaults HIGH.	
D11	R/W	* CLEAR BUFFER	0	Resets the buffer to empty.	3.4.2.2
D12	R/W	BUFFER EMPTY	1	Status flags for the active buffer. Empty, lo-quarter and hi-quarter flags are available as interrupt events.	3.4.2.3
D13	RO	BUFFER LOW QUARTER	1		
D14	RO	BUFFER HIGH QUARTER	0		
D15	RO	BUFFER FULL	0		
D16	R/W	BUFFER OVERFLOW	0		
D17	R/W	FRAME OVERFLOW	0	Set HIGH when data is written to a closed buffer. **	
D18	R/W	ISOLATE TRIG OUT	0	Each control bit configures the corresponding external pin pair as a static Logic-LOW output.	3.13
D19	R/W	ISOLATE DAC CLK OUT	0		
D20	R/W	ISOLATE CLOCK IO	0		
D21-D31	RO	(Reserved)	0	Inactive. Returns all-zero.	---

\* Clears LOW automatically when operation is completed.

\*\* Remains HIGH until cleared by a direct write as LOW, or by initialization.

**Table 3.4-6. Active Buffer Size**

SIZE[3:0]	BUFFER SIZE (Total Channel Values)	SIZE[3:0]	BUFFER SIZE (Total Channel Values)
0	8	8	2048
1	16	9	4096
2	32	A	8192
3	64	B	16384
4	128	C	32768
5	256	D	65536
6	512	E	131072
7	1024	F	262144

**Table 3.4-7. Sample Rate Control Register**  
 Offset: 0008h Default: 0000\_0096h

DATA BIT	MODE	DESIGNATION	DESCRIPTION
D00	R/W	RATE 00	Least significant rate bit
D01-D16	R/W	RATE 01 - RATE 16	Intermediate rate bits
D17	R/W	RATE 17	Most significant rate bit
D18-D31	RO	---	Inactive. Returns all-zero.

**Table 3.4-8. Sample Rate Selection**

Nrate ( RATE[15..0] )		SAMPLE RATE Fsamp *
(Dec)	(Hex)	(Samples per Second)
100	00064	450,000
101	00065	445,545
102	00066	441,176
---	---	Fsamp (Hz) = 45,000,000 / Nrate
---	---	
---	---	
262142	3FFFE	171.663
262143	3FFFF	171.662

\* ±0.015 percent.

**Table 3.6-1. Interrupt Event Selection**

**BCR Bits D10..D08**

**Default: 0000\_0000h**

INTERRUPT A[2:0]	INTERRUPT CONDITION
0	Idle. Interrupt disabled unless initializing. Default state.
1	Autocalibration completed
2	Output buffer empty
3	Output buffer low-quarter (buffer less than 1/4-full)
4	Output buffer high-quarter (buffer 3/4-full)
5	Burst Trigger Ready
6	Load Ready (LOW-to-HIGH transition)
7	End Load Ready (HIGH-to-LOW transition of Load Ready)

**Table 3.9-1. Typical DMA Register Configuration; Block Mode**

PCI Offset	PCI Register	Function	Typical Value
80h	DMA Mode	Bus width (32); Interrupt on done	0002 0D43h
84h	DMA PCI Address	Initial PCI data source address	*
88h	DMA Local Address	Initial (constant) local address	0000 0018h
8Ch	DMA Transfer Byte Count	Number of bytes in transfer	*
90h	DMA Descriptor Counter	Transfer direction (PCI bus to Local bus)	0000 0000h
A8h (D7:0)	DMA Command/Status	Command and Status Register	01h 03h (See Text)

\* Determined by specific transfer requirements.

**Table 3.9-2. Typical DMA Register Configuration; Demand Mode**

PCI Offset	PCI Register	Function	Typical Value
80h	DMA Mode	Bus width (32)	0002 1943h
84h	DMA PCI Address	Initial PCI data source address	*
88h	DMA Local Address	Initial (constant) local address	0000 0018h
90h	DMA Descriptor Counter	Transfer direction (PCI bus to Local bus)	0000 0000h
A8h (D7:0)	DMA Command/Status	Command and Status Register	01h 03h (See Text)

\* Determined by specific transfer requirements.

**Table 3.10-1. Adjustable Reference Frequency Control Register**

**Offset: 0000 001Ch**

**Default: 0000 0000h**

BIT FIELD	ACCESS MODE	DESIGNATION	DESCRIPTION
D[08:00]	R/W	CLOCK RATE ( <b>Nclk</b> )	Controls the frequency of the adjustable clock..
D[09]	R/W	SELECT ALTERNATE REFERENCE	Selects an alternate frequency source for the clocking rate generator (Table 3.10-2).
D[31:10]	RO	(Reserved, read-only)	(Inactive)

**Table 3.10-2. Multiboard Clocking Configurations**

SELECT ALTERNATE REFERENCE	EXTERNAL CLOCK (BOR)	CLOCK I/O PIN FUNCTION		LOCAL RESPONSE	TYPICAL APPLICATIONS
		DIRECTION *	FUNCTION		
0	0	Output	45MHz Master Clock	INITIATOR: Internal rate generator operates from the 45MHz master clock.	Synchronize external targets to the local master clock.
1	0	Output	Adj Ref	INITIATOR: Internal rate generator operates from the adjustable reference frequency.	Synchronize external targets to the local adjustable reference.
0	1	Input	DAC Clock	TARGET: Outputs update directly from the external DAC clock.	Clock local outputs from an external initiator.
1	1	Input	Ext Ref	TARGET: Internal rate generator operates from the external reference frequency.	Synchronize local rate generator clocking to an external initiator.

\* See Section 3.13 for control outputs isolation provisions.

**Table 3.11-1. Assembly Configuration Register**

Offset: 0000 0010h

Default: 00XX XXXXh

BIT FIELD	DESCRIPTION
D00-D11	Firmware Revision
D12-D15	(Reserved bit field)
D15	16AO16C if high. (firmware 012 and Higher)
D16-D17	Number of output channels 0 => (Reserved) 1 => 8 Channels 2 => 12 Channels 3 => 16 Channels
D18-D19	Output filter frequency: 0 => No filters (>300kHz) 1 => 10 kHz 2 => 100 kHz 3 => (Reserved).
D20	Differential outputs if High, Single-ended outputs if Low.
D21	Master clock frequency is 45.000MHz if Low; custom if High.
D22	Product identifier (16AO16 firmware 005 and Higher): Low => PMC66-16AO16; High => PCI66-16AO16FLV.
D23	High-Level Outputs (Differential) if High. Normal levels if Low.
D24-D31	(Reserved bit field; returns all-zero)

**APPENDIX B**

**MIGRATION FROM THE PCIe-16AO16**

## APPENDIX B

### MIGRATION FROM THE PCIe-16AO16

Operation of the PCIe-16AO16C is the same as the PCIe-16AO16. This appendix summarizes the principal similarities and differences between the two products, and is provided as a general guide rather than a comprehensive list of requirements.

#### B.1. Comparison of Features

Table B.1 lists the principal differences between PCIe-16AO16 and PCIe-16AO16C characteristics.

**Table B.1. PCIe-16AO16, PCIe-16AO16C Features Comparison**

Parameter	PCIe-16AO16	PCIe-16AO16C
Form Factor	PCI Express short card	PCI Express short card
Maximum Output Channels	16	16
Output Configuration	Balanced Differential or Single-Ended (Factory Options)	Balanced Differential or Single-Ended (Factory Options)
Output Ranges	$\pm 10V, \pm 5V, \pm 2.5V$ or $\pm 1.25V$	$\pm 10V, \pm 5V, \pm 2.5V$ or $\pm 1.25V$
Output Range Selection	Software-selectable	Software-selectable
Max Clocking Rate	450KSPS	450KSPS
Maximum Buffer Size	256K-Samples	256K-Samples
Sync I/O Logic Levels	Software-selected; LVDS or TTL	Software-selected; LVDS or TTL
Clocking Mode	Simultaneous or Sequential	Simultaneous or Sequential
Control Bus Interface	<b>PCIe; Single-lane</b>	<b>PCIe; Single-lane</b>
Local Clock Frequency	45MHz	45MHz
Internal Rate Divider	18 Bits	18 Bits
Analog Output Disconnects	No	Yes
Local Bus Controller	PLX PEX8311	PLX PCI9056 + IDT TSi381 (TSi381 is a transparent bridge)

## **Revision History:**

03-02-2022: Origination.

Copyright (C) 2005 General Standards Corp.

Additional copies of this manual or other General Standards Co. literature may be obtained from:

General Standards Corp.  
8302A Whitesburg Dr.  
Huntsville, Alabama 35802  
Telephone: (256) 880-8787  
FAX: (256) 880-8788

The information in this document is subject to change without notice.

General Standards Corp. makes no warranty of any kind with regard to this material, including, but not limited to, the implied warranties of merchantability and fitness for a particular purpose. Although extensive editing and reviews are performed before release to ECO control, General Standards Corp. assumes no responsibility for any errors that may exist in this document. No commitment is made to update or keep current the information contained in this document.

General Standards Corp. does not assume any liability arising out of the application or use of any product or circuit described herein, nor is any license conveyed under any patent rights or any rights of others.

General Standards Corp. assumes no responsibility resulting from omissions or errors in this manual, or from the use of information contained herein.

General Standards Corp. reserves the right to make any changes, without notice, to this product to improve reliability, performance, function, or design.

All rights reserved.

No part of this document may be copied or reproduced in any form or by any means without prior written consent of General Standards Corp.

**General Standards Corporation**  
*High Performance Bus Interface Solutions*