

PMC66-ADADIO2

12-Channel 16-Bit Analog I/O PMC

***With 8 Simultaneous Input Channels at 100K or 200K Samples per Second per Channel,
4 Output Channels, and Byte-Wide Digital I/O Port***

Features Include:

- Advanced component upgrade, with original ADADIO functionality and I/O connector pinout
- 8 Analog input channels; 16-Bit ADC per channel. 4 Analog output channels; 16-Bit DAC per channel.
- 8-Bit Bi-directional Digital Port with two auxiliary control lines
- Auto calibration of all analog channels; On-demand; internally controlled
- Simultaneous analog input sampling; 16-Bit A/D converter per **channel**
- Analog input sample rates adjustable up to **100,000 samples per second** per channel. (**200,000 samples per second** option available.)
- 32K-Sample analog input FIFO buffer
- Continuous and Triggered-Burst input modes. Supports multiboard synchronization.
- Analog outputs disconnect from system under software control
- Simultaneous updating of outputs with hardware or software strobe
- Analog output aggregate data rates to 250K Samples per second, host dependent
- Loopback feature for built-in-test support and auto calibration
- 33MHz/66 MHz, 32-Bit PCI support, with universal 5V/3.3 signaling.
- Single-width PMC form factor
- Extended temperature range available
- VxWorks™ Driver available
- **An Enhanced version of this product is available with higher sample rates, larger buffers, buffered analog outputs, etc. See PMC66-16AISS8AO4.**

Applications:

- ✓ Supervisory Control Systems
- ✓ Data Acquisition Systems
- ✓ Research Instrumentation
- ✓ Automatic Test Equipment
- ✓ Simulators and Trainers
- ✓ Process Control

Rev: 090924

Overview:

The PMC66-ADADIO2 is a single-width PMC module which contains eight 16-Bit A/D converters, four 16-bit D/A converters, and all supporting functions necessary for adding flexible analog I/O capability to a PCI host. The board is designed for minimum off-line maintenance, and includes internal monitoring and loopback features that eliminate the need for disconnecting or removing the module from the system for calibration. All analog input and output system connections are made through a single 68-pin subminiature-D front-access I/O connector. The analog outputs can be internally disconnected from the system I/O connector under software control.

Offset and gain trimming of the 16-bit ADC and output DAC's are performed by an internal autocalibration feature. System analog inputs pass through a Selftest network that can replace the system signals either with a precision voltage standard or with the four analog output channels. This arrangement is used during autocalibration to determine the offset and gain correction parameters for the ADC, and for each of the output D/A converters. The correction parameters are stored in a calibration RAM for subsequent real-time implementation during operation. Auto calibration can be invoked at any time from the PCI bus.

Each analog output channel is accessed through an independent 16-bit data register in PCI memory space. ADC conversion data are read by the bus through an analog input FIFO buffer. An auxiliary digital port contains eight bits of bi-directional data and two control lines, and is controlled through a single register.

Communication with the host PCI bus is provided by a PCI Interface Adapter which furnishes a 32-bit local bus for exchanging information between the FIFO buffers, the adapter, and the Local Controller. All internal operations are managed by the Local Controller.

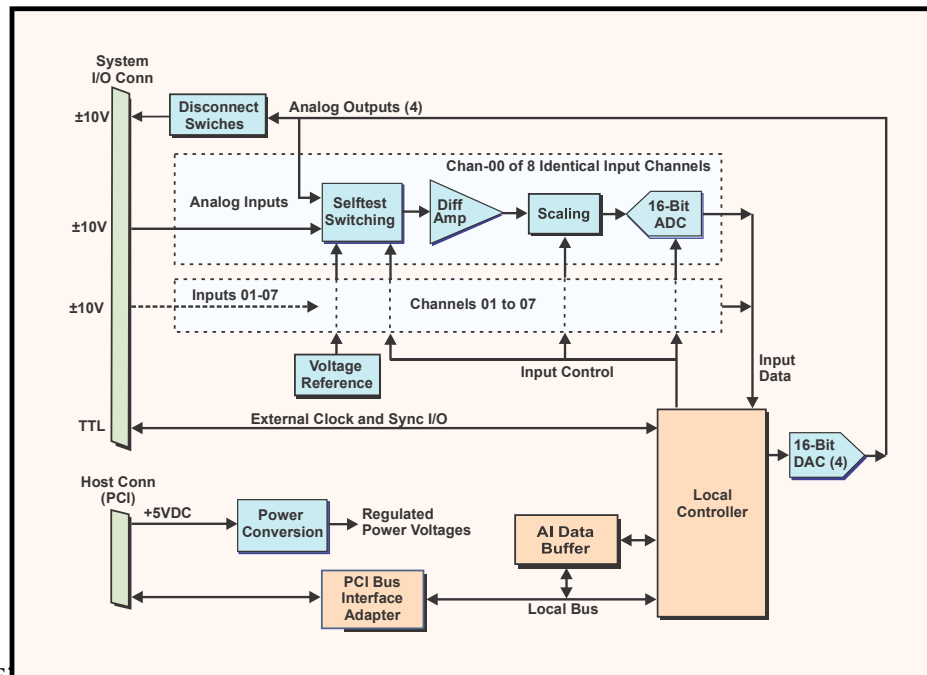

Figure 1. PMC66-ADADIO2 Analog I/O Board, Simplified Functional Diagram

This product is functionally compatible with the IEEE PCI local bus specification Revision 2.3. System input/output connections are made at the front panel through a high-density 68-Pin I/O connector. Power requirements consist of +5 VDC, in compliance with the PCI specification, and operation over the specified temperature range is achieved with conventional air cooling.

ELECTRICAL SPECIFICATIONS

At +25 °C, with specified operating conditions

ANALOG INPUT CHANNELS

□ **Input Characteristics:**

Configuration:	8 differential or single-ended input channels; software selected
Voltage Ranges:	Factory configured as ± 10 Volts.
Input Impedance:	1.0 Megohms in parallel with 20 pF; 2.0 Megohms line-to-line
Common Mode Rejection:	75 dB minimum, DC-60 Hz (Differential mode)
Common Mode Range:	± 11.0 Volts; with zero input signal level
Offset Voltage:	± 1.0 millivolts, maximum
Signal to Noise Ratio (SNR):	88dB 10 Hz to 20 kHz; 80 dB to 100 kHz. Reference = Fullscale input signal.
Remote Ground Sensing:	All single-ended inputs are measured relative to the external return, which is isolated from the internal analog return by approximately 200 Ohms.
Overvoltage Protection:	± 30 Volts with power applied; ± 15 Volts with power removed
External Trigger Input:	TTL level, active LOW

□ **Transfer Characteristics:**

Resolution:	16 Bits (0.0015 percent of FSR)
Conversion Rate	305 Hz to 100KSPS per channel, controlled with a 16-bit integer (170- 100KSPS in burst and multiboard sync modes). At very low rates (below 150SPS) the conversion cycle time is 9 μ s. For 200KSPS maximum sample rate, contact Sales.
Accuracy:	± 0.007 percent of reading, ± 0.006 percent of Full-Scale-Range, ± 1.0 mV. e.g.: ± 2.6 mV, while reading +5 Volts on the ± 10 V range (20V FSR).
Crosstalk Rejection:	80dB minimum; DC-1000Hz
Integral Nonlinearity:	± 0.006 percent of FSR, maximum
Differential Nonlinearity:	± 0.003 percent of FSR, maximum
External Trigger Latency:	Single card: 0.25 μ s maximum; Multiboard synchronization: 0.35 μ s

□ **Analog Input Operating Modes and Controls**

Input Sampling Mode:	<u>Continuous Conversion Mode</u> (Default): Analog inputs are converted continuously at the selected conversion rate. Inputs are software selected as differential or single-ended. <u>Burst Scan Mode</u> : A single conversion of selected channels is initiated by an external hardware trigger or by a software trigger. Applies in both differential or single-ended modes. <u>Loopback Mode</u> : Connects a selected analog output channel to all input channels. <u>Reference Modes</u> : Used during calibration verification. Replace system inputs with an internal reference voltage or with signal return
----------------------	--

General Standards Corporation

8302A Whitesburg Drive · Huntsville, AL 35802

Phone: (256) 880-8787 or (800) 653-9970 FAX: (256) 880-8788 Email: Solutions@GeneralStandards.com

□ **Analog Input Operating Modes and Controls (Continued)**

Active Channels:	Software selected from 1 to 8 channels. Conversion data from active channels appear in the analog input buffer. Active channels are contiguous, beginning with Channel-0 and proceeding upward to the highest active channel number.
Data Buffer:	FIFO buffer with a capacity of 1 to 32,768 samples. Buffer size is software selected in 2:1 ratios with a 4-bit register field.
Buffer Flags:	Buffer empty, buffer half full and buffer full. Corresponding interrupts supported.
Data Format:	Software selected as offset binary or two's complement format
Multiboard Synchronization:	A single initiator card can be used to trigger synchronized conversions in up to three target cards.

ANALOG OUTPUT CHANNELS

□ **Output Characteristics:**

Configuration:	Four single-ended output channels
Voltage Ranges:	Factory configured as ± 10 Volts (Same range as inputs)
Output Resistance:	1.0 Ohm, maximum if outputs are enabled; 22 kOhms to ground if outputs are disabled
Output protection:	Withstands sustained short-circuiting to ground. Also withstands overvoltage transients to ± 40 Volts through 80 Ohms for 10 milliseconds.
Load Current:	± 5 mA maximum; ± 2 mA recommended for minimum crosstalk and line loss
Load Capacitance:	Stable with zero to 2000 pF shunt capacitance
Noise:	1.4 mVrms, 10Hz-10MHz

□ **Transfer Characteristics:**

Resolution:	16 Bits (0.0015 percent of FSR)
Maximum Sample Rate:	250K channels per second, typical aggregate rate. Useable rate is host-dependent.
Accuracy (No load):	± 0.007 percent of setting, ± 0.005 percent of Full-Scale-Range, ± 1.0 mV. e.g.: ± 2.4 mV, while generating +5 Volts on the ± 10 V range (20V FSR). Add ± 1.0 mV per milliamp of loading.
Settling Time (0.01%):	No output filter: 25 us
Crosstalk Rejection:	75 dB minimum, DC-1000Hz
Integral Nonlinearity:	± 0.007 percent of FSR, maximum
Differential Nonlinearity:	± 0.003 percent of FSR, maximum
External Strobe Input:	TTL level, active LOW

□ **Analog Output Operating Modes and Controls**

- Output Strobing: When software configured for output strobing, all outputs are updated simultaneously in response to a software strobe or to an external hardware strobe.
- Output Enabling: Analog outputs are connected to the system I/O connector if analog outputs are enabled, or are disconnected if analog outputs are disabled.
- Data Registers: 16-bit data register per output channel
- Data Format: Software-selected as offset binary or two's complement format

DIGITAL I/O PORT

- Configuration: 8 bidirectional data lines and two control lines. One control line is a dedicated output, the other control line is a dedicated input. All lines use standard TTL logic levels.
- Data and Control Register: Single 16-bit register
- Transfer Rate: Typically 10^6 transfers per second, host-dependent

CALIBRATION

During autocalibration, all analog channels are calibrated against a single precision internal voltage reference. The reference is adjustable with a single internal trimmer, or by an external remote trimmer. Analog outputs are disabled during autocalibration, which has a typical duration of four seconds.

PCI INTERFACE

- **Compatibility:** Conforms to PCI Specification 2.3; D32, 33/66MHz, Universal 3.3V/5V signaling. Supports "plug-n-play" initialization. Provides multifunction interrupt. Supports 2-Channel DMA transfers as bus master; block and demand modes.

MECHANICAL AND ENVIRONMENTAL SPECIFICATIONS

❑ **Power Requirements**

+5VDC \pm 0.2 VDC at 1.5 Amp, maximum, 1.4 Amp typical

Maximum Power Dissipation: 6.5 Watts, Side 1
 1.0 Watt, Side 2

❑ **Physical Characteristics (PMC Form Factor)**

Height: 13.5 mm (0.53 in)
Depth: 149.0 mm (5.87 in)
Width: 74.0 mm (2.91 in)
Shield: Side 1 is protected by an EMI shield.

❑ **Environmental Specifications**

Ambient Temperature Range: Operating: 0 to +65 degrees Celsius inlet air
 Storage: -40 to +85 degrees Celsius

Relative Humidity: Operating: 0 to 80%, non-condensing
 Storage: 0 to 95%, non-condensing

Altitude: Operation to 10,000 ft.

Cooling: Conventional convection cooling; 50 LFPM minimum air flow

ORDERING INFORMATION

- **For a 100KSPS maximum sample rate, specify the model number as PMC66-ADADIO2-311.**
- **For a 200KSPS maximum sample rate, specify the model number as PMC66-ADADIO2-312. Contact Sales for availability.**

General Standards Corporation

8302A Whitesburg Drive · Huntsville, AL 35802

Phone: (256) 880-8787 or (800) 653-9970 FAX: (256) 880-8788 Email: Solutions@GeneralStandards.com

Table 1. System Connector Pin Functions

P5A		P5B	
PIN	SIGNAL	PIN	SIGNAL
1	OUTPUT RETURN	1	DIGITAL RETURN
2	OUTPUT CHANNEL 00	2	INPUT TRIGGER
3	OUTPUT RETURN	3	DIGITAL RETURN
4	OUTPUT CHANNEL 01	4	INPUT TRIGGER READY
5	OUTPUT RETURN	5	DIGITAL RETURN
6	OUTPUT CHANNEL 02	6	OUTPUT STROBE
7	OUTPUT RETURN	7	DIGITAL RETURN
8	OUTPUT CHANNEL 03	8	OUTPUT STROBE READY
9	INPUT RETURN	9	DIGITAL RETURN
10	INPUT RETURN	10	I/O DATA 00
11	INPUT CHANNEL 00 LO (-)	11	DIGITAL RETURN
12	INPUT CHANNEL 00 HI (+)	12	I/O DATA 01
13	INPUT CHANNEL 01 LO (-)	13	DIGITAL RETURN
14	INPUT CHANNEL 01 HI (+)	14	I/O DATA 02
15	INPUT CHANNEL 02 LO (-)	15	DIGITAL RETURN
16	INPUT CHANNEL 02 HI (+)	16	I/O DATA 03
17	INPUT CHANNEL 03 LO (-)	17	DIGITAL RETURN
18	INPUT CHANNEL 03 HI (+)	18	I/O DATA 04
19	INPUT CHANNEL 04 LO (-)	19	DIGITAL RETURN
20	INPUT CHANNEL 04 HI (+)	20	I/O DATA 05
21	INPUT CHANNEL 05 LO (-)	21	DIGITAL RETURN
22	INPUT CHANNEL 05 HI (+)	22	I/O DATA 06
23	INPUT CHANNEL 06 LO (-)	23	DIGITAL RETURN
24	INPUT CHANNEL 06 HI (+)	24	I/O DATA 07
25	INPUT CHANNEL 07 LO (-)	25	DIGITAL RETURN
26	INPUT CHANNEL 07 HI (+)	26	I/O CONTROL INPUT
27	VREF RETURN	27	DIGITAL RETURN
28	VREF ADJUST REFERENCE	28	I/O CONTROL OUTPUT
29	VREF RETURN	29	DIGITAL RETURN
30	VREF REMOTE ADJUST	30	DIGITAL RETURN
31	VREF RETURN	31	DIGITAL RETURN
32	RANGE VREF	32	DIGITAL RETURN
33	VREF RETURN	33	DIGITAL RETURN
34	VREF RETURN	34	DIGITAL RETURN

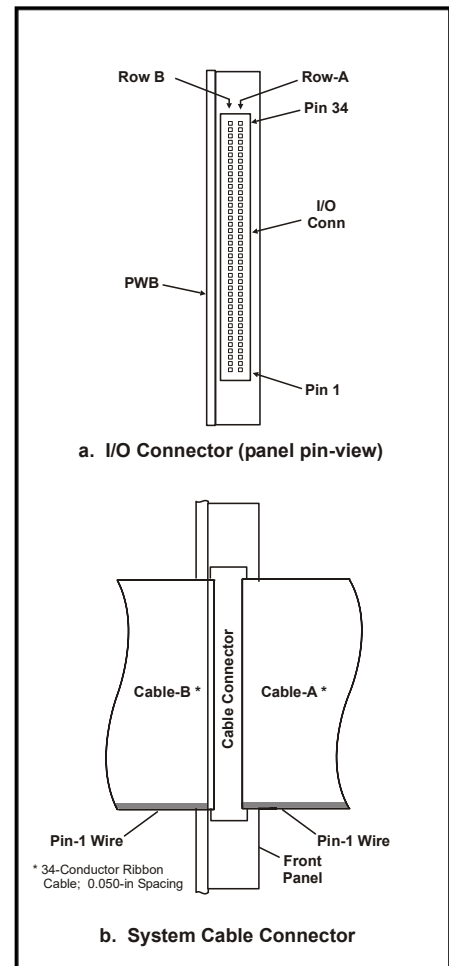

Figure 2. System I/O Connector

System Cable Mating Connector:
 68-pin 0.050" Subminiature connector: with metal shield:
 AMP #749621-7 or equivalent.

I/O Connector Installed on Board
 (Ref): Amp # 787170-7

General Standards Corporation assumes no responsibility for the use of any circuits in this product. No circuit patent licenses are implied. Information included herein supersedes previously published specifications on this product and is subject to change without notice.

General Standards Corporation

8302A Whitesburg Drive · Huntsville, AL 35802

Phone: (256) 880-8787 or (800) 653-9970 FAX: (256) 880-8788 Email: Solutions@GeneralStandards.com